

SINGER

46W61, 46W62 & 47W61 to 47W67

INSTRUCTIONS
FOR USING AND ADJUSTING
SINGER
SEWING MACHINES

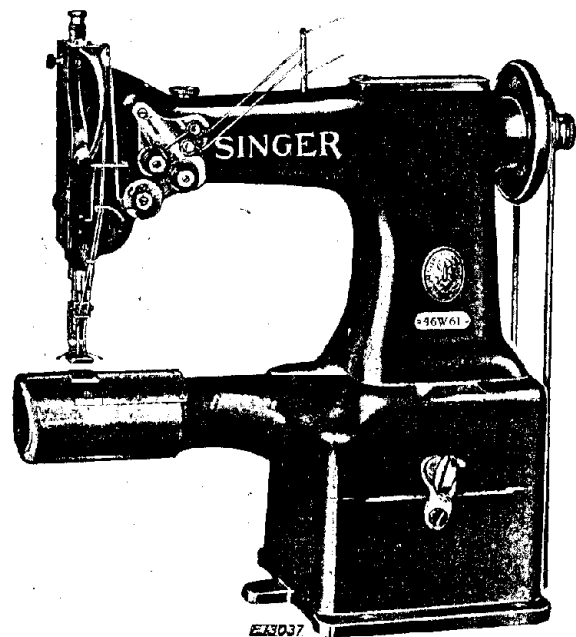

46w61, 46w62 and 47w61 to 47w67

CYLINDER BED

HIGH SPEED

THE SINGER MANUFACTURING CO.

TO ALL WHOM IT MAY CONCERN:

The improper placing or renewal of the Trade-Mark "SINGER" or any other of the Trade-Marks of The Singer Manufacturing Company (all of which are duly Registered Trade-Marks) on any machine that has been repaired, rebuilt, reconditioned, or altered in any way whatsoever outside a Singer factory or an authorized Singer agency is forbidden.

THE IMPORTANCE OF USING GENUINE "SINGER" PARTS AND NEEDLES IN "SINGER" MACHINES

The successful operation of SINGER machines can only be assured if genuine SINGER parts and needles are used. Supplies are available at all Singer Shops for the Manufacturing Trade, and mail orders will receive prompt attention.

Genuine SINGER Needles should be used in SINGER Machines.
These Needles and their Containers are marked with the Company's Trade Mark "SIMANCO." 1

Needles in Containers marked "FOR SINGER MACHINES" are NOT "SINGER" made needles. 2

DESCRIPTION

Machines of Class 46w

Machines of Class 46w each have two needles and two belt driven rotary sewing hooks and simultaneously make two parallel lines of lock stitching. The distance between the two needles may be from $\frac{1}{32}$ " to $\frac{1}{2}$ ", as ordered. The machines have a cylinder bed and are used for stitching tubular, concave or other irregularly shaped articles in cloth or leather. Following are descriptions of the individual machines:

Machine 46w61 is intended for tailoring and for stitching shirts, overalls, gloves, etc. This machine has a plain presser foot and a drop feed.

Machine 46w62 is fitted with a drop feed and alternating pressers which especially adapt it for sewing sleeves to the body of coats, for stitching overalls, gloves, canvas, etc., and for tailoring. The alternating pressers are particularly effective for work where there are seams to cross.

Machines of Class 47w

Machines of Class 47w each have one needle and a belt driven rotary sewing hook and make the lock stitch. They have a cylinder bed and are used for stitching tubular, concave or other irregularly shaped articles in cloth or leather. Following are descriptions of the individual machines:

Machine 47w61 has a ball bearing roller presser and a drop feed and is especially adapted for stitching shoes, gloves and other work in leather.

Machine 47w62 has a plain presser foot and a drop feed and is intended for stitching shirts, linen and cotton underwear, pajamas, overalls and other work in light and medium weight fabrics.

Machine 47w63 has alternating presser feet and a drop feed and is especially designed for tailoring and for stitching overalls, leather gloves and for inserting sleeves into coats and jackets. The alternating pressers are particularly effective for binding work in general.

Machine 47w64 is equipped with a vertical trimmer and is intended for stitching and trimming at one operation in the manufacture of shoes, gloves and other work in light and medium weight leather. This machine is used for work where it is desired to stitch and trim both the outside and lining at the same time. The knife trims abreast of the needle and the distance from the trimmed edge to the line of stitching may be .028, .035, .045, .060 or .085 inch, as desired. Orders for the machine should specify the trimming margin required. The machine has a ball bearing roller presser and a drop feed.

Machine 47w65 is equipped with an oblique underedge trimmer and is intended for stitching and undertrimming the linings of shoes, sandals, slippers, etc., in one operation. The distance from the trimmed edge to the line of stitching may be .015, .025, .035, .040, .050 or .060 inch, as desired. When the trimming margin is .035 inch or less, the machine trims back of the needle. When the trimming margin is .040 inch or more, the machine trims abreast of the needle. Orders must state the trimming margin required. The machine has a ball bearing roller presser and a drop feed.

Machine 47w66 has alternating presser feet and a drop feed and is particularly adapted for stitching leather gloves and other work in light and medium weight leather. This machine is also used for binding shoes, slippers, etc., and for stitching gloves with roll welt gauge.

Machine 47w67 is equipped with a horizontal trimmer and edge guide and is designed for stitching the edges and undertrimming the linings of shoes, sandals, etc., in one operation. It is also used in the manufacture of gloves, pocket books, small leather cases and other articles requiring a cylinder bed and a horizontal trimmer.

To Oil the Machine

When the machine is received from the factory, it should be thoroughly cleaned and oiled.

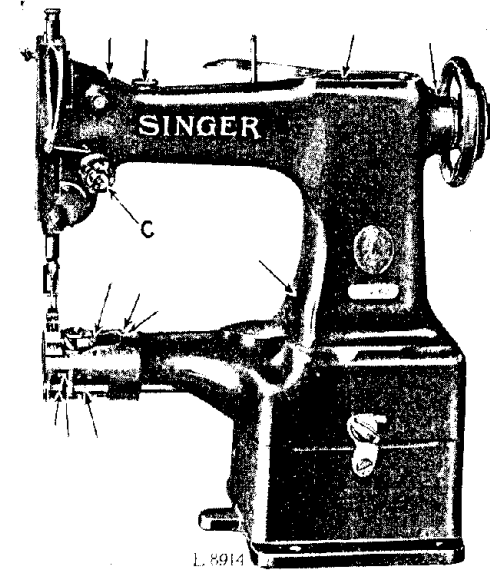

Fig. 2. Oiling Points and Adjustment at the Front of the Machine

Oil should be applied at each of the places designated by arrows in Figs. 2, 3 and 4. When the machine is in continuous use, it should be oiled at least twice each day.

Swing back the cover which is on the top of the machine at the right, and oil the bearings which are thus uncovered, then replace the cover.

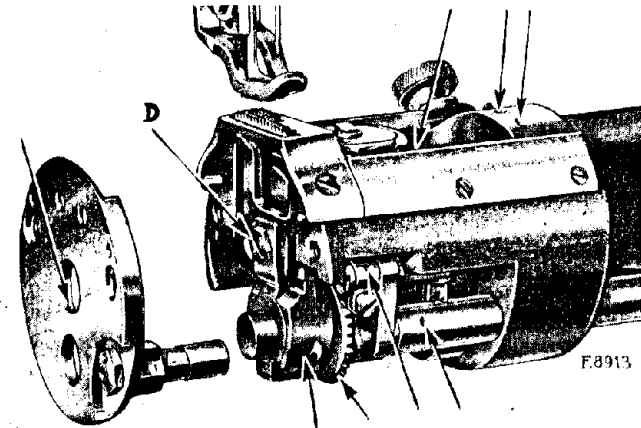

Fig. 3. Oiling Points and Adjustment in End of Cylinder

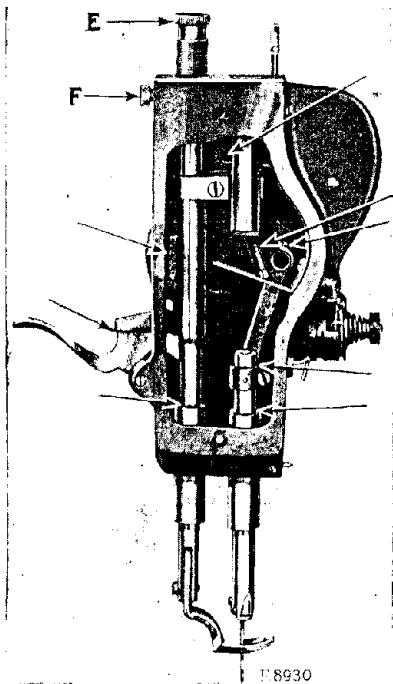

Fig. 4. End View of Machine, Showing Oiling Points and Adjustments

Move the face plate aside and oil the wick and bearings which are thus uncovered, then replace the face plate.

The small felt pad on the side of the bobbin case should be kept wet with oil to lubricate the hook race.

Speed

The maximum speeds recommended for Machines of Classes 46w and 47w are as follows:

Machine	Stitches per Minute
46w61	3000
46w62	2500
47w61	3000
47w62	3000
47w63	2500
47w64	2500
47w65	2500
47w66	2500
47w67	3000

Run the machine slower than the maximum speed until the parts which are in movable contact have become glazed by their action upon each other. When the machines are in operation, the balance wheel should always turn over toward the operator.

Needles

Needles for Machines of Classes 46w and 47w are of the Class and Variety numbers given in the following table:

MACHINE	CLASS AND VARIETY OF NEEDLES	CLOTH OR LEATHER	SHAPE OF POINT	SIZES
46w61 46w62 47w63	126x3	Cloth	Round	10, 12, 14, 16, 18, 20, 22, 23 and 24
47w61 47w64 47w65 47w66 47w67	128x2 or 128x4	Leather	Triangular	9, 10, 11, 12, 13, 14, 15, 16, 18, 20, 22 and 23
		Leather	Narrow Wedge	9, 10, 11, 12, 13, 14, 15, 16, 18, 20, 22, 23 and 24
47w62	128x3 or 128x13	Cloth	Round	9, 10, 11, 12, 13, 14, 16, 18, 20, 22, 23, 24 and 25
		Cloth	Round	9, 10, 11, 12, 13, 14, 16, 18, 20, 22, 23 and 24

Relative Sizes of Needles and Thread

The following sizes of needles and thread are recommended:

SIZES OF NEEDLES	COTTON THREAD	SILK THREAD
9, 10	70	OO and O
11	60	A
12	50	B
13	40	C
14	36	D
15	30	D
16	30	E
18	24	EE
20	20	
22	16	
23	12	
24, 25	8	

The size of the needle to be used should be determined by the size of the thread which must pass freely through the eye of the needle. If rough or uneven thread is used or if it passes with difficulty through the eye of the needle, the successful use of the machine will be interfered with.

Orders for needles must specify the quantity required, the size number, also the class and variety numbers separated by the letter x.

The following is an example of an intelligible order:

"100 No. 16, 128 x 2 Needles".

The best results will be obtained in using the needles furnished by the Singer Sewing Machine Company.

Thread

Use left twist thread for the needle. Either left or right twist thread may be used for the bobbin.

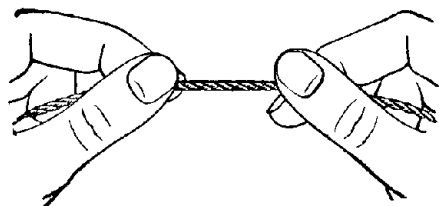

Fig. 5. How to Determine the Twist

Hold the thread as shown above. Turn the thread over toward you between the thumb and the forefinger of the right hand; if left twist, the strands will wind tighter; if right twist the strands will unwind.

To Set the Needle

In a Class 46w machine, turn the balance wheel until the needle bar is at its highest point, insert the inside needle in the needle holder with the short groove toward the inside hook, and insert the outside needle in the needle holder with the short groove toward the outside hook.

In a Class 47w machine, insert the needle in the needle bar with the short groove toward the hook.

Be sure to push the needle as far up as it will go, then tighten the set screw firmly.

It may be necessary to turn the needle slightly to the right or left for some threads if stitches are missed.

Operators are liable to use needles which are too fine. Better results will usually follow the use of a larger size.

To Remove the Bobbin

Draw out the slide plate in the bed of the machine. Insert the finger nail of the forefinger under the latch (G, Fig. 8), raise the latch and lift out the bobbin.

In a 47w65 or 47w67 machine turn the balance wheel over toward you until the needle bar moves up to its highest point. Place the thumb or finger under the projection on the side of the bobbin case cap, lift out the cap and remove the bobbin.

To Wind the Bobbin

(See Fig. 6)

Fasten the bobbin winder to the table with its driving pulley in front of the machine belt, so that the pulley will drop away from the belt when sufficient thread has been wound upon the bobbin.

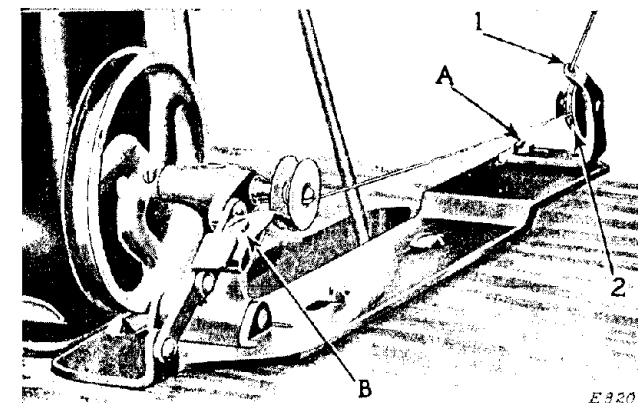

Fig. 6. Winding the Bobbin

Place the bobbin on the bobbin winder spindle and push it on as far as it will go.

Pass the thread down through the thread guide (1) in the tension bracket, around the back and between the tension discs (2). Then wind the end of the thread around the bobbin a few times, push the bobbin winder pulley over against the machine belt, and start the machine.

When sufficient thread has been wound upon the bobbin, the bobbin winder will stop automatically.

If the thread does not wind evenly on the bobbin, loosen the screw (A) in the tension bracket and move the bracket to the right or left, as may be required, then tighten the screw.

The amount of thread wound on the bobbin is regulated by the screw (B). To wind more thread on the bobbin, turn the screw (B) inwardly. To wind less thread on the bobbin, turn this screw outwardly.

Bobbins can be wound while the machine is stitching.

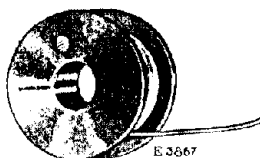

Fig. 7. Direction of Thread on Bobbin

To Replace the Bobbin and Thread the Bobbin Case

The following instructions apply to both bobbins in Machines of Class 46w.

Hold the bobbin between the thumb and forefinger of the right hand, the thread drawing on the bottom from the left toward the right (see Fig. 7), and place it on the centre stud of the bobbin case, then push down the latch as shown in Fig. 8. Draw the thread into the slot (1, Fig. 8) and back of the projection (2, Fig. 8), leaving a loose end of thread about two inches long above the slide. When closing the slide, leave just enough space for the thread to pass through.

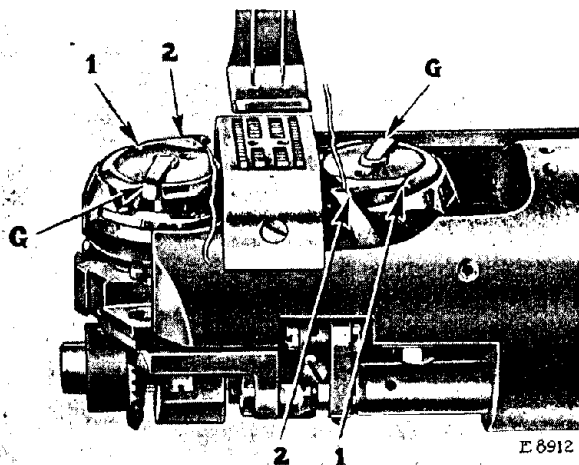

Fig. 8. Bobbin Cases of Class 46w Machine Threaded

The bobbin case in Machines of Class 47w, except 47w65 and 47w67, is threaded the same as the right hand bobbin case illustrated above.

To Thread the Bobbin Case Caps

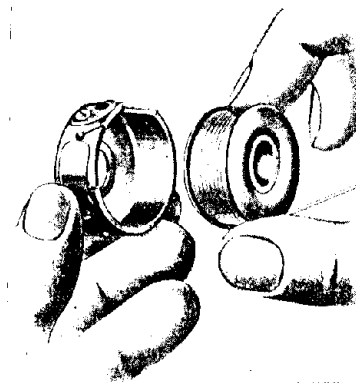

Fig. 9

With the left hand hold the bobbin case cap as shown in Fig. 9, and place the bobbin into it.

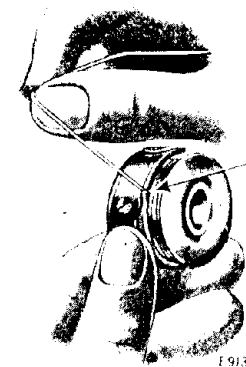

Fig. 10

Then pull the thread into the slot (1, Fig. 10) in the edge of the bobbin case cap and under the tension spring, through the slot (2, Fig. 11) and out under the thread guide 3, as shown in Fig. 11.

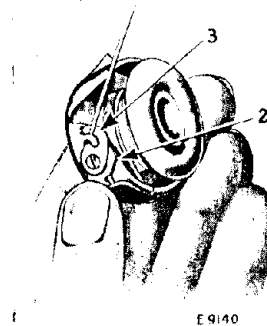

Fig. 11

To ensure the correct tension, draw the thread under the tension spring once or twice; this will remove any lint which may become lodged under the spring.

To Replace the Bobbin Case Caps

Take the cap in the right hand, holding the bobbin in the cap with the thumb and replace it on the centre stud, then push down the latch, having the thread at the left of the projection, and replace the slide plate.

To Thread the Needle in Machines of Class 47w

(See Fig. 12)

Pass the thread from the unwinder from back to front through the upper hole (1) in the pin on top of the machine, and from

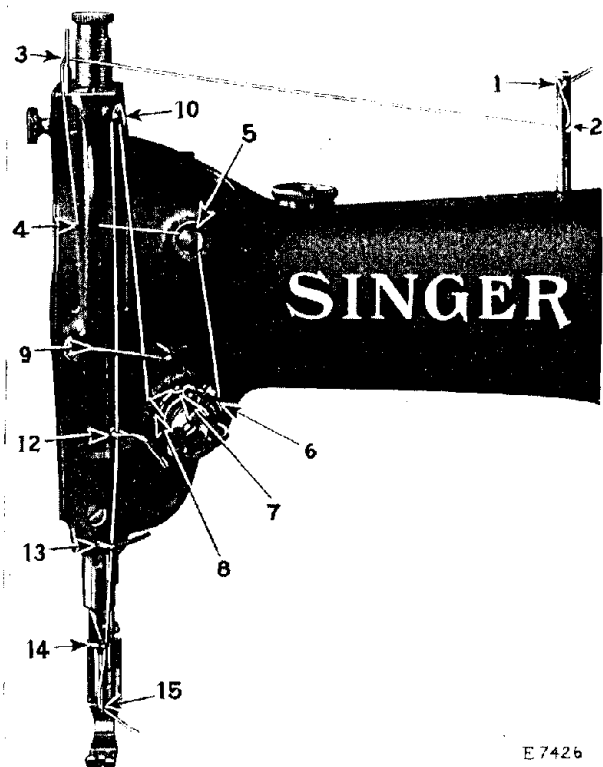

E 7426

Fig. 12. Threading the Needle in Machines of Class 47w

right to left through the lower hole (2) in the pin, from right to left through the thread guide (3), down and from left to right through the hole (4), over the top into the thread retainer (5), down, under and from right to left between the tension discs (6), up into the fork (7) above the tension discs, into the hook of the wire controller spring (8), up through the wire thread guide (9), up and from right to left through the hole (10) in the end of the thread take up lever, down through the wire guide (9) again, through the wire guides (12 and 13), into the thread guide (14) at the lower end of the needle bar and from left to right through

the eye of the needle (15). Draw about two inches of thread through the eye of the needle with which to commence sewing.

Note. When the thread is taken from a spool on the spool holder of the machine, omit the thread from the holes (1 and 2, Fig. 12) in the thread guide pin, and pass the thread directly from the spool through the thread guide (3, Fig. 12). The balance of the threading is the same as instructed on the preceding page.

On machines fitted with thread oiler, pass the thread back of the thread oiler guide.

To Thread the Needles in Machines of Class 46w

(See Fig. 13)

To thread the outside needle or the one farthest from the upright part of the arm, pass the thread from the left spool on the

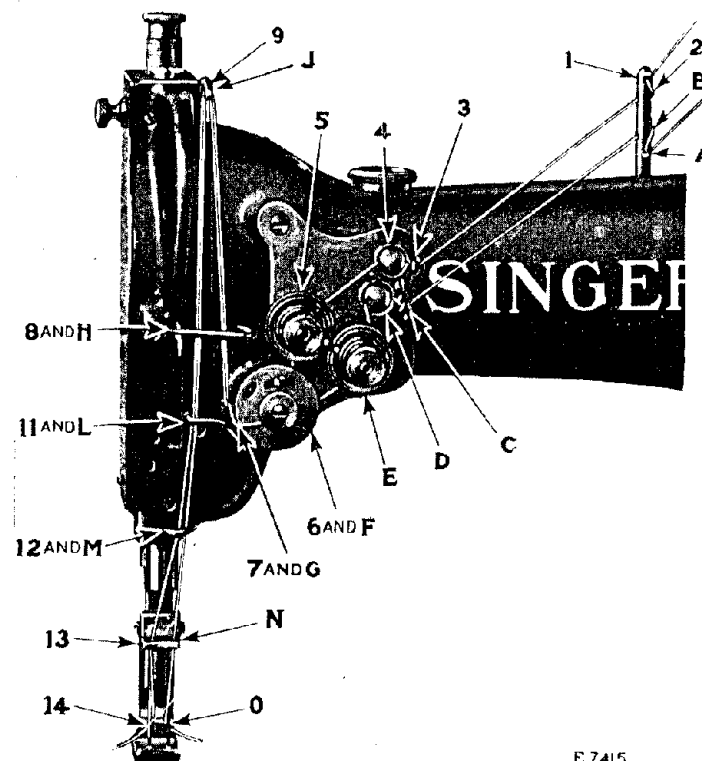

E 7415

Fig. 13. Threading the Needles in Machines of Class 46w

spool stand, through the left guide at the top of the spool stand, down and from back to front through the hole (1) in the pin on top of the machine, then from right to left through the hole (2) in the pin, into the wire thread guide (3) at the right of the upper thread retainer, through the upper thread retainer (4), over from right to left between the left tension discs (5), down under from right to left into the thread controller (6), into the thread controller spring (7) and up through the thread guide (8), up and from right to left through the upper hole (9) in the end of the thread take-up lever, down through the thread guide (8) again, and through the thread guides (11 and 12), down through the left hole (13) in the needle holder and from right to left through the eye of the left or outside needle (14).

To thread the inside needle or the one nearest the upright part of the arm, pass the thread from the right spool on the spool stand, through the right guide at the top of the spool stand, down and from back to front through the hole (A) in the pin on top of the machine, then up and from right to left through the hole (B) in the pin, into the wire thread guide (C) at the right of the lower thread retainer, through the lower thread retainer (D), under from right to left between the right tension discs (E), down under from right to left into the thread controller (F), into the thread controller spring (G) and up through the thread guide (H), up and from right to left through the lower hole (J) in the end of the thread take-up lever, down through the thread guide (H) again, and through the thread guides (L and M), down through the right hole (N) in the needle holder and from left to right through the eye of the right or inside needle (O).

Roller Presser

For convenience in threading, press down on the roller and swing it out to the left.

To Prepare for Sewing

With the left hand hold the end of the needle thread, leaving it slack from the hand to the needle. Turn the balance wheel over toward you until the needle moves down and up again to its highest point, thus catching the bobbin thread; draw up the needle thread and the bobbin thread will come up with it through the hole in the throat plate. Lay the threads back under the presser foot or roller presser and close the slides.

To Commence Sewing

Place the material beneath the presser foot or roller presser, lower the presser bar and commence to sew, turning the balance wheel over toward you.

To Remove the Work

Have the thread take-up lever at the highest point, raise the presser foot or roller presser, draw the work back and cut the threads close to the goods. Lay the ends of the threads back under the presser foot or roller presser.

Tensions

The needle and bobbin threads should be locked in the centre of the thickness of the material, thus:



Fig. 14. Perfect Stitch

If the tension on the needle thread is too tight, or if that on the bobbin thread is too loose, the needle thread will lie straight along the upper surface of the material, thus:



Fig. 15. Tight Needle Thread Tension

If the tension on the bobbin thread is too tight, or if that on the needle thread is too loose, the bobbin thread will lie straight along the under side of the material, thus:

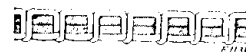

Fig. 16. Loose Needle Thread Tension

To Regulate the Tensions

The tension on the needle thread is regulated by the thumb nut (C, Fig. 2) at the front of the tension discs on the front of the machine. To increase the tension, turn this thumb nut over to the right. To decrease the tension, turn this thumb nut over to the left.

The tension on the bobbin thread is regulated by means of the screw nearest the centre of the tension spring on the outside of the bobbin case. To increase the tension, turn this screw over to the right. To decrease the tension, turn this screw over to the left.

To Regulate the Length of Stitch

The length of stitch is regulated by the feed regulating spindle head (A, Fig. 17) at the right of the balance wheel.

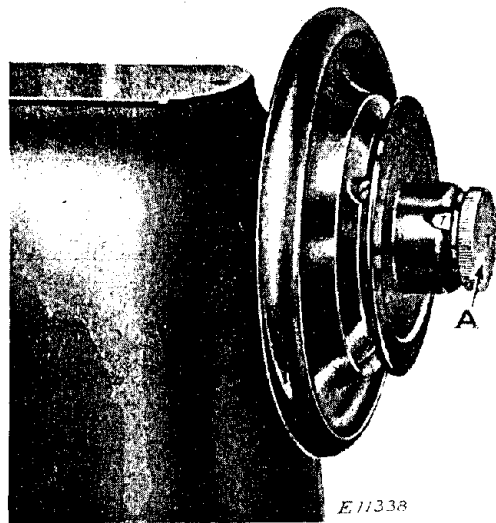

Fig. 17. Stitch Regulator

There is a notch in the hub of the balance wheel as shown in Fig. 17, and the number appearing in the notch shows the number of stitches to the inch that the machine is ready to make.

To lengthen the stitch, turn the stitch regulator (A) over toward you. To shorten the stitch, turn the stitch regulator over from you.

To Regulate the Pressure on Material

The pressure on the material is regulated by the thumb screw (E, Fig. 4) at the top of the machine. To increase the pressure, loosen the lock screw (F, Fig. 4) at the back of the machine and turn the thumb screw (E) downwardly. To decrease the pressure, turn the thumb screw (E) upwardly. When the desired pressure is obtained, securely tighten the lock screw (F). The pressure should be only heavy enough to enable the feed to move the work along freely.

To Operate the Trimmer on Machine 47w64

The knife (Y, Fig. 25) is held vertically for cutting both the outside and the lining in one operation, and may be thrown into or out of action while the stitching is in progress.

To throw the knife **out of action**, press the lever (X, Fig. 25) to the left. To throw the knife **into action**, press down on the handle (A2, Fig. 25).

To Operate the Trimmer on Machine 47w65

The knife (W, Fig. 26) is held obliquely in the correct position for cutting the linings from under the bead edge of the shoe uppers, and may be thrown into or out of action as desired, while the stitching is in progress.

To throw the knife **out of action**, press the lever (P, Fig. 26) to the left. To throw the knife **into action**, move the handle (S, Fig. 26) to the right.

To Operate the Trimmer on Machine 47w67

The trimmer is attached to the bed of the machine in a horizontal position, the cutting blade projecting downwardly at the extreme left edge, as shown at (N2, Fig. 27).

This trimmer can be used for cutting the edge of the lining from under the edge of the shoe upper or, if desired, it can be used for simultaneously cutting the edges of both the upper and under pieces of material.

To **throw the knife out of action**, raise the handle (T2, Fig. 27) and swing it toward you, as shown in Fig. 27, until it is locked out of operation. To **throw the knife into action**, move the handle (T2) back until it springs into position in the notch in the knife bracket (S2, Fig. 27).

To Adjust the Thread Lubricator on Machines 47w61 and 47w64 to 47w67

To ensure satisfactory results, **SINGER Thread Lubricant** should be used in the thread lubricator which is attached to the face plate.

When replenishing the lubricant supply, fill the reservoir (F2, Fig. 25) to about $\frac{1}{8}$ inch below the filler hole (E2, Fig. 25).

The amount of lubrication of the thread is controlled by raising or lowering the felt pad holder (D2, Fig. 25) above or below the level of the lubricant. For more lubricant, lower the felt pad holder. For less lubricant, raise the felt pad holder.

INSTRUCTIONS FOR ADJUSTERS AND MACHINISTS

Thread Controller

The function of the thread controller spring is to hold back the slack of the needle threads until the eye of each needle reaches the goods in its descent, as without this controlling action of the spring, the slack thread or silk (more especially silk) will sometimes be penetrated by the point of the needle as the needle is descending.

To Adjust the Thread Controller on Machines of Class 47w

For more controller action on the thread, loosen the stop screw (N, Fig. 18) at the right of the tension and set the stop lower, and for less action, set the stop higher.

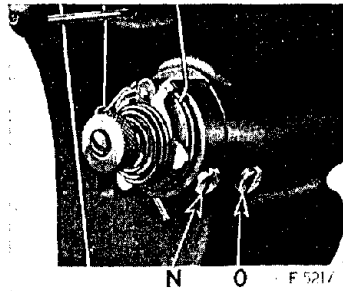

Fig. 18. Adjustments of Thread Controller on Machines of Class 47w

To strengthen the action of the controller spring on the thread, loosen the tension stud screw (O, Fig. 18) at the right of the stop screw and turn the tension stud slightly to the left with a screwdriver, or to lighten its action on the thread, turn the tension stud to the right and tighten the tension stud screw (O).

To Adjust the Thread Controller on Machines of Class 46w

To change the thread controller stop for more controller action on the threads, loosen the set screw (C3, Fig. 19) and turn

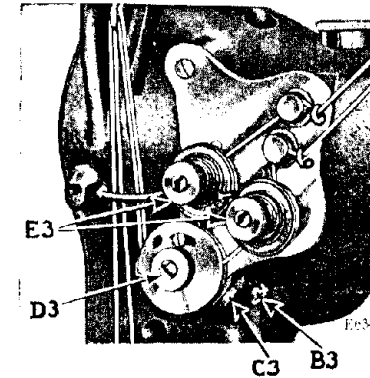

Fig. 19. Adjustment of Thread Controller on Machines of Class 46w

the thread controller spring stop to the right; for less action, turn the thread controller spring stop to the left, after which securely tighten the set screw (C3).

It may be found advisable to increase the tension of the spring for coarse thread, or to lessen it for fine thread.

To increase the tension of the thread controller on the threads, loosen the tension stud set screw (B3, Fig. 19), located nearly under the tension stud, and turn the tension stud (D3, Fig. 19) slightly to the left with a screwdriver, or to decrease the tension, turn it to the right and retighten the stud set screw (B3).

To See if the Needle Bar is Set Correctly

See that the needle is up in the bar as far as it will go. The needle bar which is in the machine when shipped from the factory has upon it (about $1\frac{1}{2}$ inches from the bottom) two lines $\frac{3}{4}$ inch apart.

When the needle bar is at its lowest position, the upper mark should be just visible at the end of the bushing.

To Set the Needle Bar in Correct Time. Loosen the needle bar connecting stud pinch screw and place the needle bar in the proper position as directed above, then retighten the screw.

To Set a Needle Bar Which Has no Mark. Set the needle bar so that when it rises $\frac{3}{4}$ inch from its lowest position the point of the hook will be at the center of the needle and about $\frac{1}{8}$ inch above the eye.

To See if the Hook is Correctly Timed

Remove the throat plate and turn the balance wheel toward you until the lower mark across the needle bar, as it is going up, is just visible at the end of the bushing; now, if the needle bar and hook are in correct time, the point of the hook will be at the center of the needle and about $\frac{1}{16}$ inch above its eye.

To Time the Hook

Loosen the screws in the hook driving gear and turn the balance wheel toward you until the needle bar goes to its lowest position and upward until the lower mark across the needle bar is just visible at the end of the bushing, then stop turning and hold the wheel firmly with the right hand, turn the hook until the point is at the center of the needle— $\frac{1}{16}$ inch above its eye—then retighten the gear set screws.

To Remove the Bobbin Case and Hook from the Machine

Take out the hook gib screws and remove the gib (H, Fig. 20) to allow the bobbin case to be taken out, after which remove the

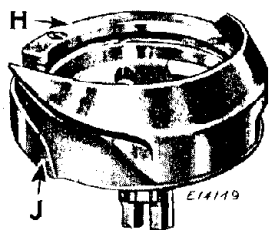

Fig. 20. Sewing Hook Removed from Machine, Showing Oiling Wick and Hook Washer (Needle Guard)

screw from the centre of the hook. Tap the hook lightly on the bottom of its rim to force it from its socket. Do not try to pry it out, as prying may bend the shank of the hook. When replacing the hook, be sure that the prongs of the shank properly enter the slot at the top of the socket, otherwise the hook will be out of time. Then replace the screw in the centre of the hook, replace the bobbin case and securely fasten the hook gib in position by means of the screw.

To Set the Hook To or From the Needle

To prevent the point of the sewing hook from dividing the strands of the thread, it should run as close to the needle (within the scarf) as possible.

If the sewing hook runs too far from or too close to the needle, loosen the hook saddle screws (K, Fig. 21) just enough to permit the saddles to be driven by light blows to the position desired, then retighten the hook saddle screws.

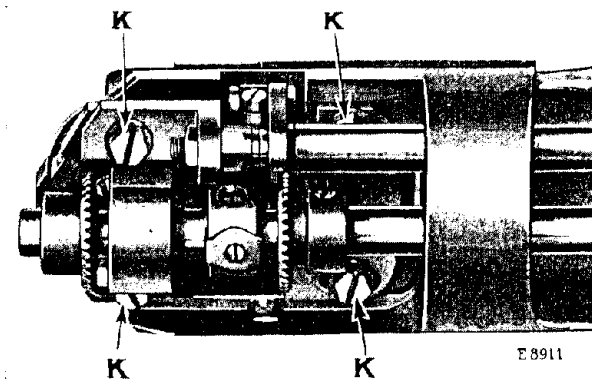

Fig. 21. Adjustment of Hook Saddles

Needle Guard

The function of the hook washer (J, Fig. 20), which is attached to the bottom of each sewing hook, is to prevent the point of the hook from striking the needle, if, when passing through the material, the needle is deflected towards the hook.

The upright portion of the hook washer should be sprung with a screwdriver or other instrument until it prevents the hook point from striking the needle, it should not however be sprung outwardly enough to deflect the needle from its normal path.

Adjustment of Feed Regulating Spindle Head

The figures on the feed regulating spindle head, showing through the notch in the balance wheel, indicate the number

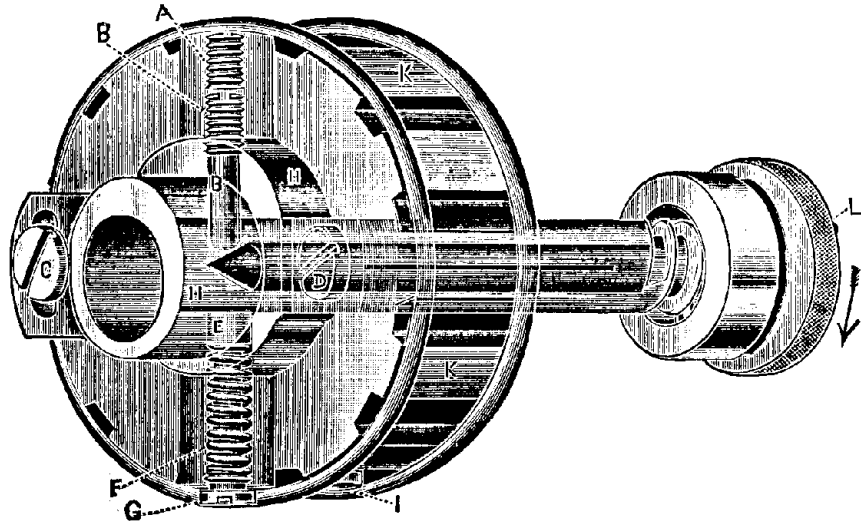

Fig. 22. Transparent view through the arm shaft connection belt pulley and shaft, showing the feed regulating spindle and adjusting screw (B), which comes in contact with the cone of the spindle to gauge the length of stitch.

of stitches to the inch which should be made. If more or less stitches are made, adjust as follows: Remove screw (A, Fig. 22), set the indicator at 8 and the feed dog at its highest point, a full tooth showing above the throat plate, then adjust screw (B) until eight stitches to the inch is the result and replace check screw (A) firmly, making the master adjustment, which controls the other numbers of stitches as indicated.

To Set the Feed Regulator so that a Stitch Longer than the One desired Cannot be made. Turn spindle head (L, Fig. 22) toward you and make the longest stitch possible; remove check screw (A) and turn screw (B) until the machine makes the desired number of stitches to the inch, then turn screw (A) down tightly on screw (B) as a check. The stitch may then be changed by turning spindle head (L) for a shorter stitch, but operators cannot make longer stitches than the limit that screw (B) is set to produce.

To Adjust the Feed Dog

Usually when the feed dog is at its highest position, it should show a full tooth above the throat plate. To raise or lower the feed dog, remove the cylinder end cover, loosen the feed dog screw (D, Fig. 3) and adjust the feed dog to the required height, then securely tighten the feed dog screw (D).

If the feed dog strikes the throat plate, tip the machine back and loosen the pinch screw (R, Fig. 24) of the feed driving rock shaft crank at the end of the rock shaft, then set the feed dog so that it will not strike when the longest stitch is made, and retighten the pinch screw (R).

To Adjust the Mechanical Opener

The bobbin case lever (Q, Fig. 23) at the left of the sewing hook, actuated by the eccentric on the hook washer, strikes the

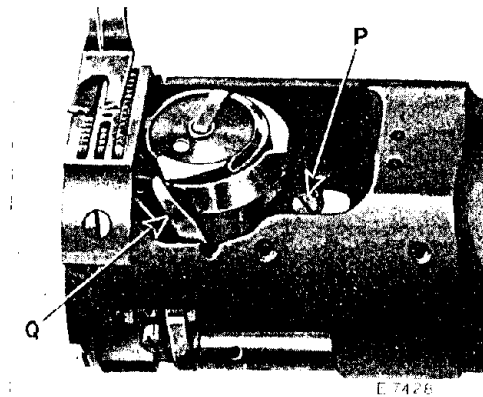

Fig. 23. Adjustment of Mechanical Opener

projection on the bobbin case and turns the bobbin case slightly, making an opening between the bobbin case stop and the stop on the throat plate when the thread is across the bobbin case and passing between the stops.

The bobbin case lever (Q) may be adjusted by loosening the bobbin case lever fulcrum screw (P, Fig. 23) and moving the fulcrum forward or backward.

This adjustment should be made so that the opening between the lever and the edge of the bobbin case is just perceptible when the bobbin case lever has opened the bobbin case all the way.

If the bobbin case lever is set to open the bobbin case too far, it will cause a bind between the bobbin case bearing and the hook bearing when the bobbin case is opened all the way, and care must be taken to see that this does not occur. When the correct adjustment of the bobbin case lever (Q) is made, securely tighten the fulcrum screw (P).

The above instructions apply to both bobbin cases in Machines of Class 46w, with the exception that the bobbin case lever for the left bobbin case is located at the right of the left sewing hook.

To Remove the Arm Shaft Connection Belt from Within the Arm

Slide the arm shaft connection belt off the lower pulley (S, Fig. 24). Remove the feed regulating spindle head and balance

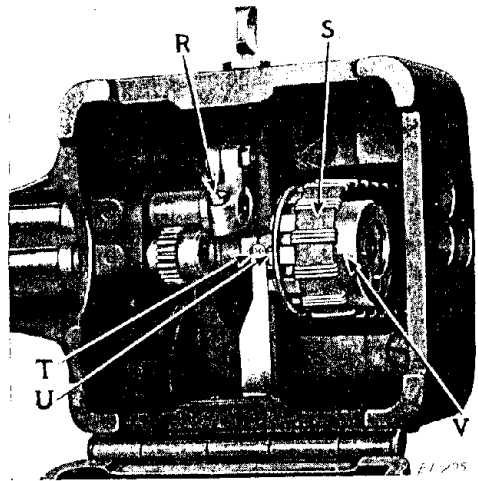

Fig. 24. Underside of Machine, Showing Arrows on Plate and Collar for Determining Correct Position of Hook Driving Shaft when Replacing Belt on Lower Pulley with Belt Replacer 241538

wheel. Loosen the arm shaft bushing (back) screw at the back of the arm and remove the bushing. Lift the belt up through the arm cap hole as far as possible and draw it out through the space normally occupied by the bushing.

Owing to the fact that the sewing hook makes two revolutions to one revolution of the arm shaft, and that the feed lifting eccentric is on the hook shaft, it is possible to have the sewing hook correctly timed without having the feed eccentric correctly timed. To overcome this, the plate (T, Fig. 24) is attached to the underside of the bed of the machine. This plate is marked with

an arrow at its forward end and directly alongside of the plate, the side of one of the teeth of the belt pulley is marked as shown at U in Fig. 24. When replacing the belt, replace the arm shaft bushing and securely fasten it in position by the screw at the back of the machine, replace the feed regulating spindle head and the balance wheel and place the belt on the upper pulley, then turn the balance wheel over toward you until the thread take-up lever is at its highest point. Then turn the hook driving shaft with the fingers until the arrow on the plate (T) and the timing mark on the belt pulley (U) are directly in line. Now, without disturbing either the arm shaft or the hook driving shaft, slip the belt over the lower pulley (S, Fig. 24). The feed will then be correctly timed with the needle bar.

To facilitate the replacing of the belt on the lower pulley, use belt replacer 241538 (V, Fig. 24). Rest the replacer in the loop of the belt and slide it over the hub of the pulley, as shown in Fig. 24, having the notches in the replacer engage the two set screws in the hub of the pulley. Turn the balance wheel toward you until the belt is fully over the pulley, then remove the replacer.

Note: As belt replacer 241538 will serve for several machines, it is not regularly furnished with the machine, and must be ordered separately.

To Change the Trimming Margin on Machines 47w64 and 47w65

The distance from the trimmed edge to the line of stitching is determined by the throat plate used, each throat plate having but one trimming margin.

The trimming margin is measured from the centre of the needle hole to the cutting edge of the throat plate.

To change from one trimming margin to another it is only necessary to change the throat plate and adjust the knife.

Throat Plates for Machine 47w64 Vertical Trimmer

THROAT PLATE NO.	SIZE OF NEEDLE HOLE	SIZES OF NEEDLES	TRIMMING MARGIN
233837 trims abreast of needle	60	8, 9	.028" .035" .045" .060" .085"
233838 trims abreast of needle	56	10, 11	.035" .045" .060" .085"
233839 trims abreast of needle	53	12, 13	.045" .060" .085"

**Throat Plates for Machine 47w65
Oblique Underedge Trimmer**

THROAT PLATE NO.	SIZE OF NEEDLE HOLE	SIZES OF NEEDLES	TRIMMING MARGIN
233858 trims back of needle	53	12, 13	.015"
233860 trims back of needle	53	12, 13	.025"
233861 trims back of needle	53	12, 13	.035"
233863 trims abreast of needle	53	12, 13	.040"
233865 trims abreast of needle	53	12, 13	.050" .060"

Note. The throat plate cannot have a large needle hole and a narrow trimming margin.

Orders for throat plates should specify which trimming margin is required.

To Change the Trimming Margin on Machine 47w67

The distance from the trimmed edge to the line of stitching is determined by the throat plate needle plate used, each throat plate needle plate having but one trimming margin.

The trimming margin is measured from the centre of the needle hole to the cutting edge of the throat plate needle plate.

To change from one trimming margin to another, it is only necessary to change the throat plate needle plate and adjust the knife.

**Throat Plate Needle Plates for Machine 47w67
Horizontal Trimmer**

THROAT PLATE NEEDLE PLATE	SIZE OF NEEDLE HOLE	TRIMMING MARGIN
233922	56	.035"
241730	56	.045"

**To Adjust the Trimmer on
Machine 47w64**

The knife (Y, Fig. 25) should be set so that its cutting edge presses against and just passes below the cutting edge of the throat plate cutting bar to ensure making a shear cut. Care should be taken to keep the knife sharp.

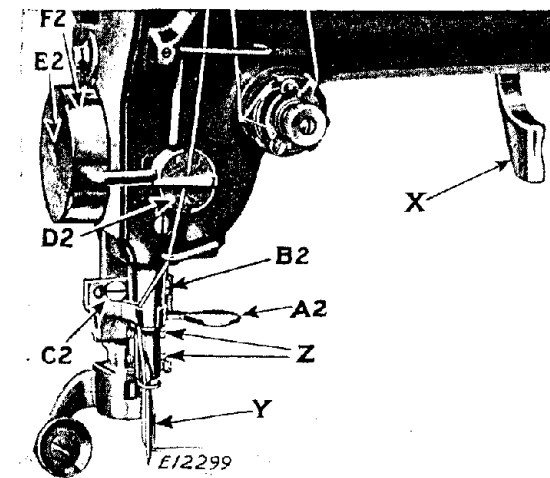

Fig. 25. Adjustments on the Trimmer of
Machine 47w64

The sidewise adjustment of the knife is made by loosening the two screws (B2 and C2, Fig. 25) and moving the knife holder to the right or left, as may be required, after which the two screws (B2 and C2) should be securely tightened.

To adjust the knife to the correct height, loosen the two screws (Z, Fig. 25) and move the knife up or down on the knife holder, after which securely tighten the two screws (Z).

To Adjust the Trimmer on Machine 47w65

The knife (W, Fig. 26) should be set so that its cutting edge presses against and just passes below the cutting edge of the throat plate cutting bar to ensure making a shear cut. Care should be taken to keep the knife sharp.

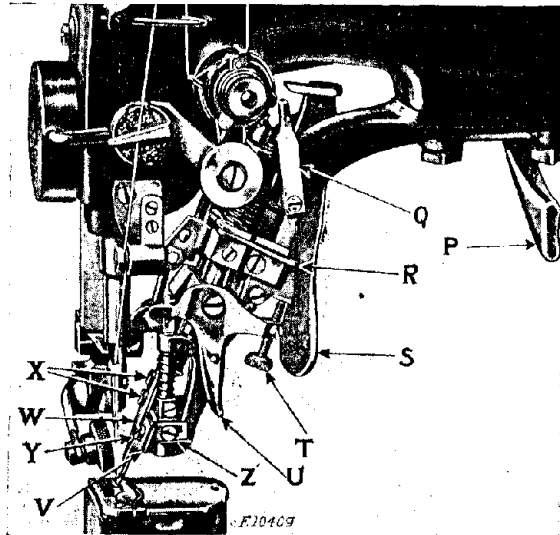

Fig. 26. Adjustments on the Trimmer of
Machine 47w65

There are two positions on the knife holder for the knife, one for trimming back of the needle which is necessary when the trimming margin is .035 inch or less, and the other for trimming abreast of the needle when the trimming margin is .040 inch or more.

If the position of the knife is altered from trimming abreast to back of the needle or vice versa, a throat plate that will receive the knife in its new location must be substituted for the one in the machine, and a change of guide fingers must also be made to protect the bead edge of the shoe upper from injury.

The sidewise adjustment of the knife is made by loosening the lock screw at the back of the knife bar and moving the knife holder to the right or left, as may be required, after which the lock screw should be securely tightened.

The knife can be adjusted to the correct height by loosening the two screws (X, Fig. 26) and moving the knife up or down on the knife holder, after which the two screws (X) should be securely tightened.

To Adjust the Edge Guide Finger on Machine 47w65

The purpose of the edge guide finger (V, Fig. 26) is to keep the edge of the shoe upper out of range of the trimming knife, thus preventing the knife from cutting the edge of the upper while the stitching and trimming is in progress. When in proper adjustment the edge guide finger should be slightly to the left of the knife (W, Fig. 26). The sidewise adjustment of the edge guide finger is obtained by loosening the screw (Z, Fig. 26) and moving the guide finger holder to the right or left as may be required, after which the screw (Z) should be firmly tightened. The back edge of the guide finger should stand as close to the knife as possible without striking it, this adjustment is obtained by loosening the screw (Y, Fig. 26) and moving the guide finger backward or forward as may be required. The guide finger should be adjusted to a height that will permit the facing or lining to pass freely under it to the knife while protecting the edge of the upper from injury. The guide finger can be adjusted to the correct height by means of the screw (T, Fig. 26). If the guide finger should run under or catch the lining, the guide finger holder should be slightly raised. To hold the guide finger out of action, hang up the guide finger bar by means of the latch (Q, Fig. 26).

When crossing heel seams, it is sometimes desirable to slightly raise the edge guide finger (V, Fig. 26). To do this, press the lever (U, Fig. 26) to the left and hold it in this position until the seam is crossed.

When it is desired to use the edge guide (V, Fig. 26) with the knife out of action, move the lever (R, Fig. 26) to the left. When it is desired to automatically raise the edge guide finger with the knife, move the lever (R) to the right when the knife is down.

To Adjust the Edge Guide on Machine 47w67

The edge guide (O2, Fig. 27) can be adjusted so that the knife will trim the edge of the under piece of material from flush up to $\frac{1}{8}$ inch under the edge of the upper piece. To change the margin from the edge to the line of stitching on the upper ply of leather, loosen the screw (B3, Fig. 27) and move the edge guide (O2) to the right or left until the desired margin is obtained, then securely tighten the screw (B3).

To disengage the edge guide (O2, Fig. 27), swing it toward the operator as far as it will go.

To Adjust the Trimmer on Machine 47w67

The knife (N2, Fig. 27) should be set so that it presses lightly against the throat plate needle plate. The knife can be adjusted

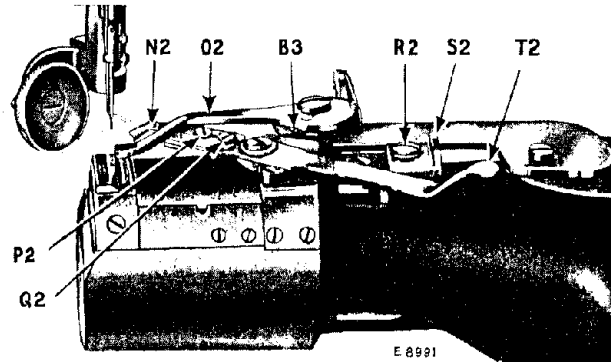

Fig. 27. Adjustments on the Trimmer of Machine 47w67

to the correct endwise position by loosening the two screws (P2 and Q2, Fig. 27) and moving the knife to the right or left on the knife holder, as required, after which securely tighten the two screws (P2 and Q2).

The radial adjustment of the knife (to and from the operator) is made by loosening the screw (R2, Fig. 27) and moving the knife bracket forward or backward, as required, after which securely tighten the screw (R2).

To Time the Trimmer on Machine 47w67

The knife (N2, Fig. 27) should be timed so that it is at its most forward position toward the operator and $\frac{1}{32}$ inch in front

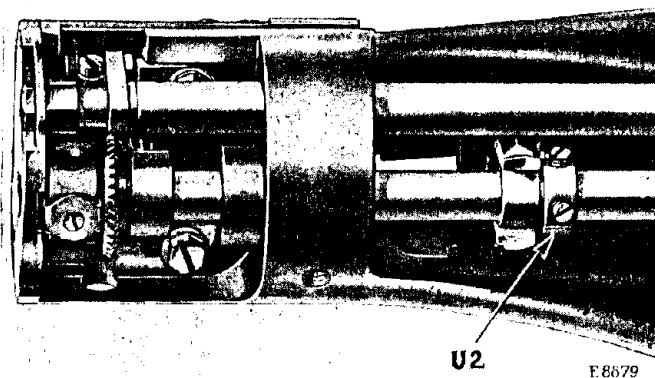

Fig. 28. Underside of Machine 47w67, Showing Adjustment for Timing the Knife

of the needle when the needle bar is at its lowest point. In case the knife is not correctly timed, loosen the two set screws in the eccentric (U2, Fig. 28) and turn this eccentric on the shaft until the correct timing of the knife is obtained, then securely tighten the two set screws in the eccentric (U2).

To Sharpen the Knife Used in Machines 47w64 and 47w65

When it is necessary to resharpen the knife, loosen the two screws which fasten the knife to the knife holder and remove the knife. Knife hone 259420 should be used to sharpen the knife. As one hone can be used for several machines, it should be ordered separately.

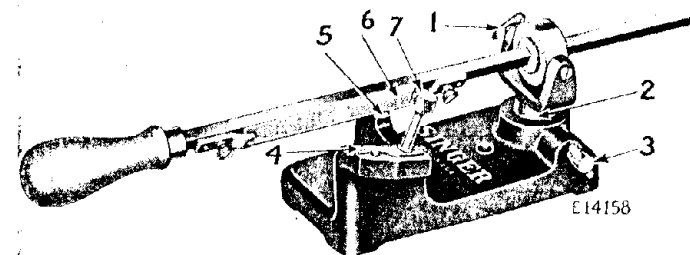

Fig. 29. Knife Hone Set at Proper Angle

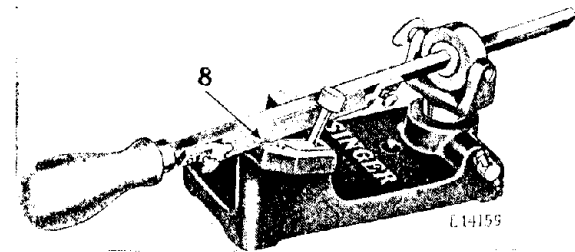

Fig. 29A. Knife Hone with Knife in Position Ready to Sharpen

To set the hone at the proper angle, loosen the wing screw (1, Fig. 29), rest the stone (6, Fig. 29) on the flat of the leveling surface (5, Fig. 29), then tighten the wing screw.

Loosen the adjusting screw (3, Fig. 29), raise or lower the guide yoke (2, Fig. 29) to get the bevel desired on the knife (4, Fig. 29), then securely tighten the adjusting screw (3).

Loosen screw (7, Fig. 29) and slide knife (4) into position as shown in Fig. 29, then tighten screw (7).

Place hone in position as shown (8, Fig. 29A) and proceed to hone knife. Care should be taken not to press down too heavily on the knife. Sharpen the cutting edge of the knife on the beveled side only, and remove as much from the projection as from the cutting edge so as to maintain their relative proportions, and to prevent the projection from striking the hook.

To Sharpen the Knife Used in Machine 47w67

When it is necessary to resharpen the knife (N2, Fig. 27), loosen the screws (P2 and Q2, Fig. 27) and remove the knife from the knife holder. Knife Hone 259283 should be used to sharpen the knife. As this hone can be used for several machines, it should be ordered separately.

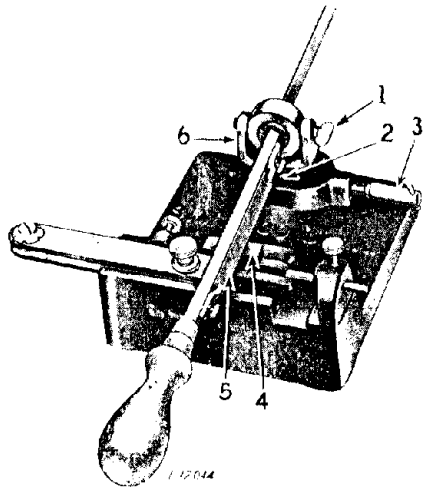

Fig. 30. Setting Hone at Proper Angle

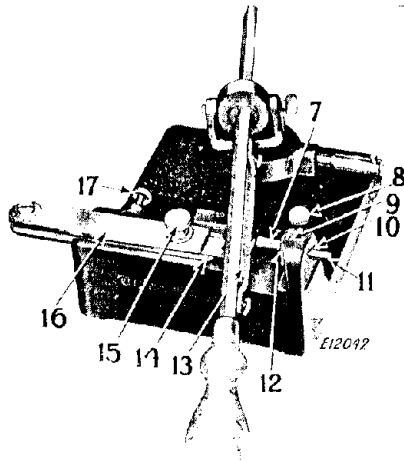

Fig. 31. Knife Hone 259283 with Knife in Position Ready to Sharpen

To set the hone at the proper angle, loosen the wing screw (1, Fig. 30), rest the stone (5, Fig. 30) flat on the leveling surface (4, Fig. 30), then tighten the wing screw (1).

Loosen the adjusting screw (3, Fig. 30) and set the yoke (6, Fig. 30) as low as it will go while the end of the adjusting screw (3, Fig. 30) remains on the flat of the yoke bushing (2, Fig. 30), then securely tighten the adjusting screw (3, Fig. 30).

For 30° cutting angle knives the lower knife stop pin (7, Fig. 31) should be set flush with the outside surface of the casting (10, Fig. 31) so that the pin extends to the left toward the knife holder slide. Larger cutting angles may be obtained by moving the knife stop pin (7, Fig. 31) to the right. When flush with the inside surface of the casting (12, Fig. 31), the cutting angle will be honed to 45°.

The knife stop pin (11, Fig. 31) not being used should be set as far as possible to the right, then tighten screws (8 and 9, Fig. 31).

Clamp knife into position on knife holder (14, Fig. 31) and tighten thumb screw (15, Fig. 31), slide holder (16, Fig. 31) into position on base until knife rests against the stop pin (7, Fig. 31), tighten knife holder set screw (17, Fig. 31), place hone (13) in position as illustrated in Fig. 31 and proceed to hone knife. Care should be taken not to press down too heavily on the knife.