

INSTRUCTION MANUAL

FOR

SINGER

MACHINES

457A	105
	125
	135
	143A

THE SINGER COMPANY

CONTENTS

	Page
Application	2
Notes on safety	2
Commissioning	2
Oiling	2
Needle and thread	3
Inserting the needle	3
Winding the bobbin	3
Threading the bobbin case	3
To remove the bobbin case	4
Threading the machine	4
Regulating the needle thread tension	5
Regulating the pretension	5
Regulating the bobbin thread tension	5
Regulating the take-up spring	5
Regulating the presser foot pressure	5
Regulating the stitch length	6
Selecting the needle position (457A105/125/135)	6
Setting the stitch width (457A105/125/135)	6
Setting the sitich width (457A143)	6
Regulating the amount of oil flow to sewing hook	7
Installing the belt guard	7
Specification	8
Machine care	8

APPLICATION

High speed single needle lock stitch zigzag machine.
High speed single needle lock stitch zigzag machine with automatic thread trimmer.

NOTES ON SAFETY

The machine must only be commissioned in full knowledge of the instruction manual and operated by persons with appropriate training.

Before putting into service also read the safety notes and the instruction manual of the motor supplier.

The machine must be used only for the purpose intended. Use of the machine without the safety devices belonging to it is not permitted.

When gauge parts are exchanged (e.g. needle, presser foot, needle plate, feed dog and bobbin), during threading, when the workplace is left, and during service work, the machine must be isolated from the mains by switching off the main switch or disconnecting the mains plug.

On mechanically operated clutch motors without start inhibitor it is necessary to wait until the motor has stopped.

General servicing work must be carried out only by appropriately trained persons.

Repairs, conversion and special maintenance work must only be carried out by technicians or persons with appropriate training.

For service or repair work on pneumatic systems the machine must be isolated from the compressed air supply system. Exceptions to this are only adjustments and function checks made by appropriately trained technicians.

Work on the electrical equipment must be carried out only by electricians or appropriately trained persons.

Work on parts and systems under electric current is not permitted, except as specified in regulations EN50110.

Conversions or changes to the machine must be made only on adherence to all safety regulations.

For repairs, only replacement parts approved by us must be used.

Commissioning of the sewing head is prohibited until such time as the entire sewing unit is found to comply with EC regulations.

Meanings of the symbols:



Danger spot!
Items requiring special attention



Danger of injury to operative or service staff
Be sure to observe and adhere to these safety notes!

COMMISSIONING



To avoid disturbances or damages it is absolutely necessary to observe the following instructions:

Before you put the machine into operation for the first time clean it thoroughly, and oil it well (see page 2).

Have the machine check whether the motor can be used with existing mains voltage or not, and that junction box is correctly connected. Do not start the machine if the voltage is not correct!

When the machine runs, the balance wheel must rotate toward the operator. If it does not, have the electrician change the wires on the motor.

OILING

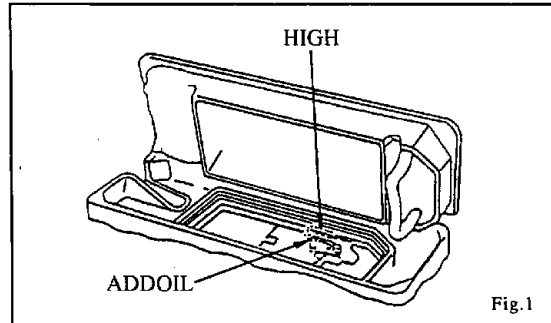

Fig.1

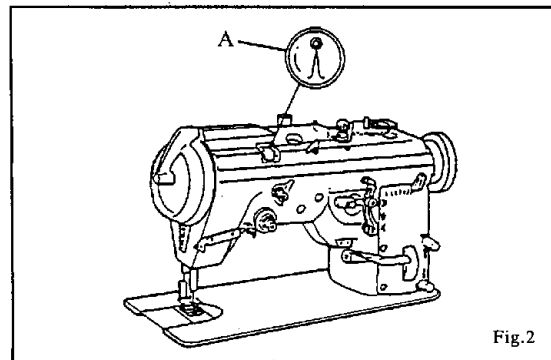

Fig.2



Switch off the machine.
Set sewing head upright again using both hands.
Danger of crushing between sewing head and table top.

Tip machine back on its hinges and fill the oil reservoir to HIGH mark as illustrated in Fig.1.

Correct lubrication is indicated by a continuous stream of oil passing the oil flow window A while machine is running, as shown in Fig.2.

Should this oil flow become erratic, STOP the machine and check the reservoir oil level, fill if needed.

At least twice each month, check the oil level in the reservoir. Never allow the oil level to drop below add oil mark, shown in Fig.1.

Only use oil with a viscosity of 20.0 mm²/sec. at 38^oC and a density of 0.888g/cm³ at 15^oC. We recommend SINGER C-oil.

NEEDLE AND THREAD

Size of needle should be determined in accordance with the size of thread used and type of material being sewn. A correct size needle will permit the thread to pass freely through the eye of the needle and avoid strain and breaking. A bent needle will cause your machine to skip stitches. A hook or hurr on the needle point will result in a finish that looks blurred and when short stitches are used some materials may be cut. Therefore, to obtain best sewing results, use SINGER needles.

Application of class		For light-weight materials	For medium-weight materials
Max. thread ▲ size-synthetic	Metric No.	120 - 100	100 - 60
	Cotton No.	80 - 60	60 - 30
Needle size	JIS(SINGER)	#8 - #10	#12 - #16
	Metric	60 - 70	80 - 100
Catalog No.(Needle system)		1906-01 (135x53)	1906-07 (135x53 M Ball)
▲ or an equivalent size of other type of thread			

INSERTING THE NEEDLE(See Fig.3)

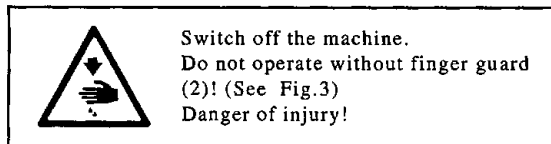
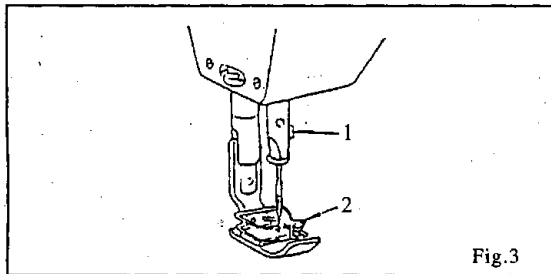

Use cat No. 1906-01 (135 X 53), 1906-07 (135 X 53 M Ball) needles only. (See table page.)

Set the needle bar at its highest point. Loosen needle set screw (1). (see Fig.3) Insert the needle in the needle bar and push it up as far as it will go. Make sure its long groove faces toward the front. Tighten needle set screw (1) securely.

WINDING THE BOBBIN (See Fig.4)

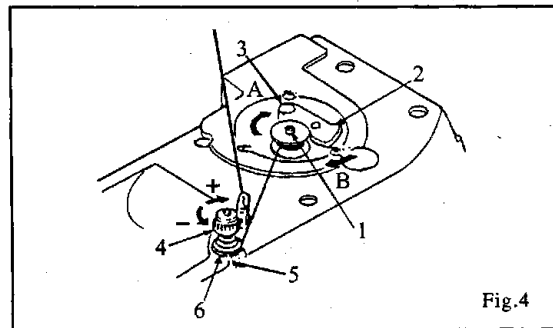

Bobbin winder spindle (1) rotates in the direction of arrow (A).

Push lever (2) in the direction of arrow (B) to wind the bobbin. To adjust amount of thread on bobbin, loosen set screw (3) in lever (2) and move lever (2), as required. Securely tighten set screw (3).

Adjust the thumb nut (4) to regulate the tension for bobbin winding.

If thread winds unevenly on bobbin, loosen screw (5) and move bobbin winder pretension (6) up or down, as required, and tighten screw (5).

THREADING THE BOBBIN CASE

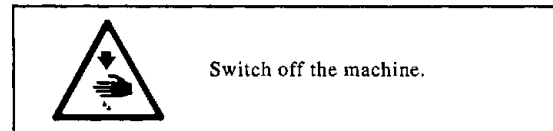
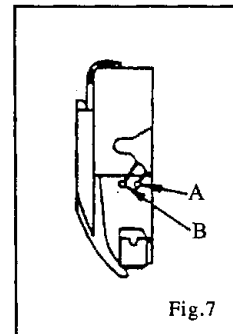
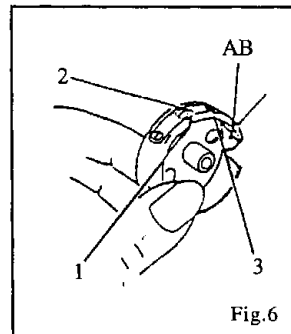
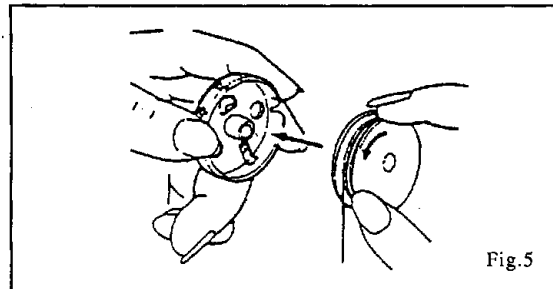

Hold bobbin so that thread will unwind in the direction shown in Fig.5 and place the bobbin into bobbin case.

Pull the thread into slot (1) and under the tension spring (2) and into slot (3) as shown in Fig.6. Then draw thread into delivery eye (A or B), as shown in Fig.6. Use delivery eye (A) for sewing light weight material, as shown in Fig.7.

Use delivery eye (B) for sewing medium weight material.

TO REMOVE THE BOBBIN CASE

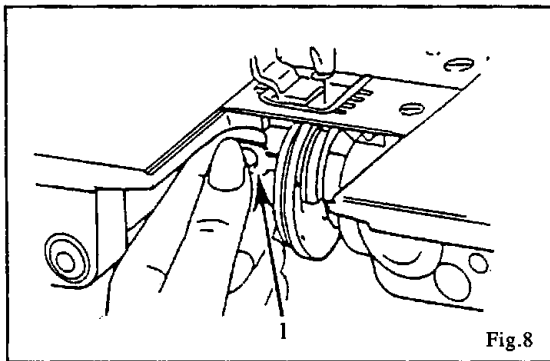
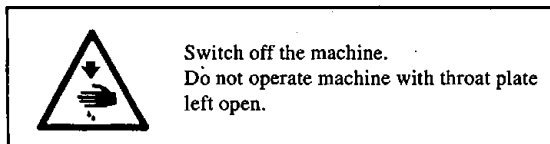

Fig. 8



Open latch (1) and remove bobbin case from sewing hook. (Fig. 8)

THREADING THE MACHINE

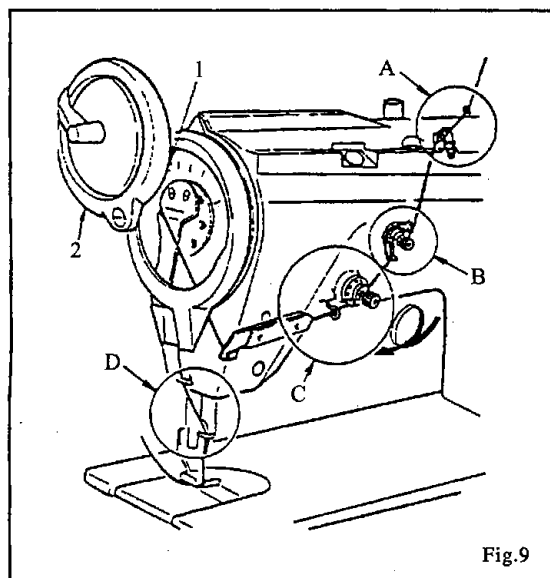

Fig. 9

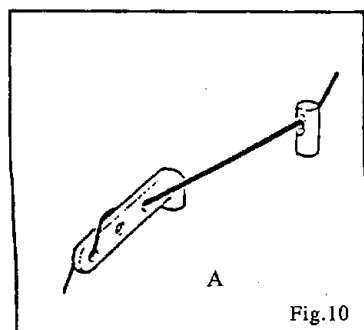

Fig. 10

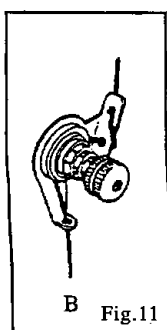

Fig. 11

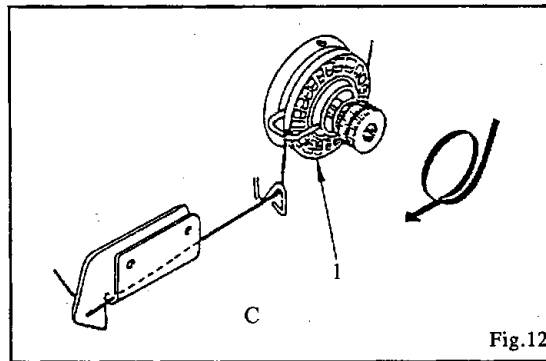

Fig. 12

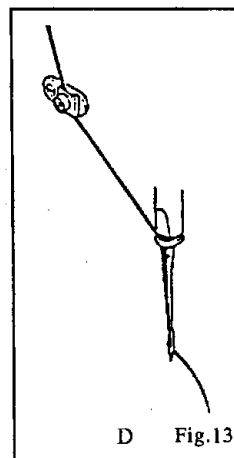
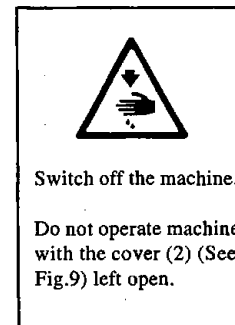

Fig. 13



Check and make sure no thread is caught in the rotary take-up before threading the machine.

CAUTION: Be careful not to injure your fingers with the thread cutter (1), Fig. 9, on the face plate when threading the rotary take-up.

Pass the thread from the unwinder through threading points A (Fig. 10), B (Fig. 11), C (Fig. 12) and D (Fig. 13) in the order shown.

NOTE: When passing thread through threading point C (Fig. 12), wind thread around rotary tension wheel (1) once.

REGULATING THE NEEDLE THREAD TENSION

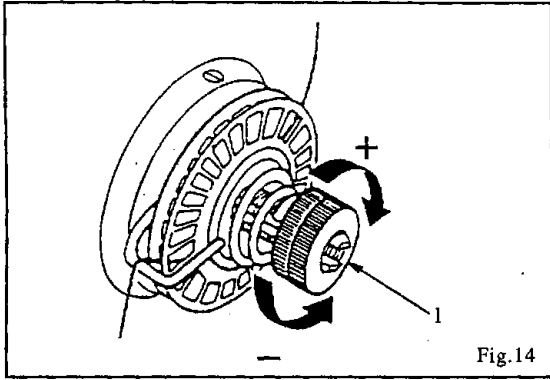

Regulate needle thread tension with tension regulating thumb nut (1) as shown in Fig.14.

REGULATING THE PRETENSION

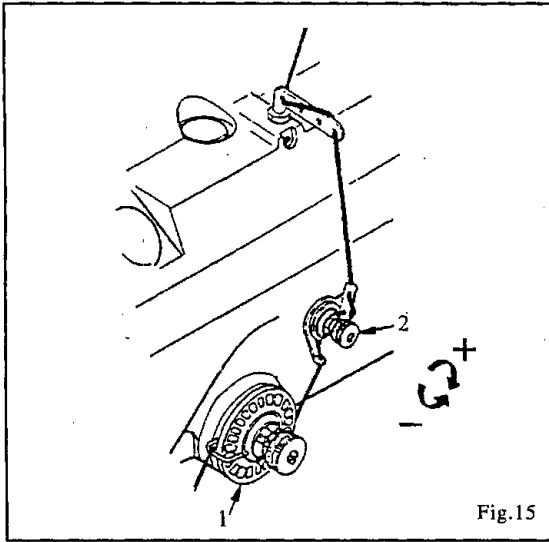

Pretension thumb nut (2) should be adjusted so that the needle thread will rotate the rotary tension wheel (1) without slippage. (Fig.15)

REGULATING THE BOBBIN THREAD TENSION

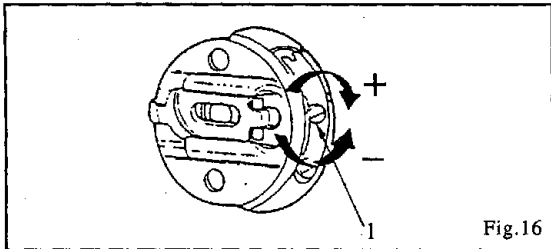

Regulate bobbin thread tension with tension regulating screw (1) as shown in Fig.16.

REGULATING THE TAKE-UP SPRING

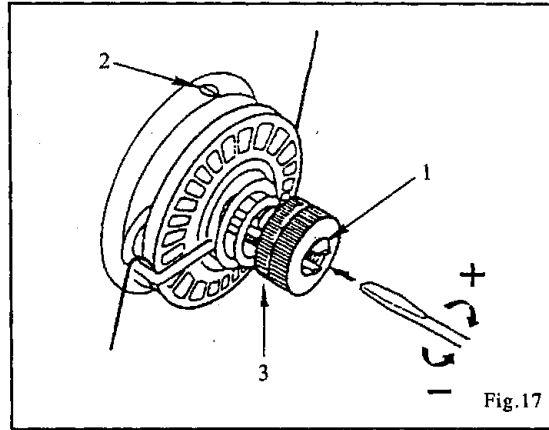

Using a large screwdriver in slot of stud (1), regulate take-up spring tension by turning stud (1), as required.

To adjust the amount of take-up spring movement, loosen screw (2), Fig.17, and set take-up spring height by turning the entire tension assembly (3) toward left or right, as required. Securely tighten screw (2).

REGULATING THE PRESSER FOOT PRESSURE

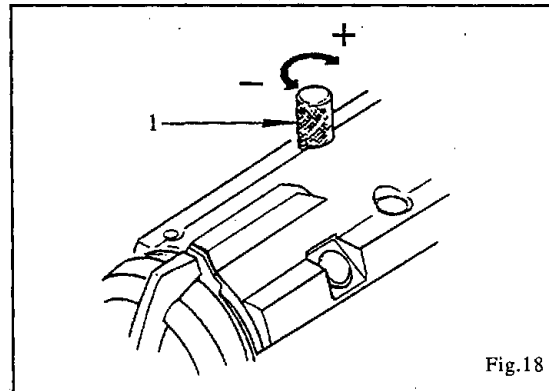

To regulate the presser foot pressure, turn knurled thumb screw (1), Fig.18, toward left of right as required.

REGULATING THE STITCH LENGTH

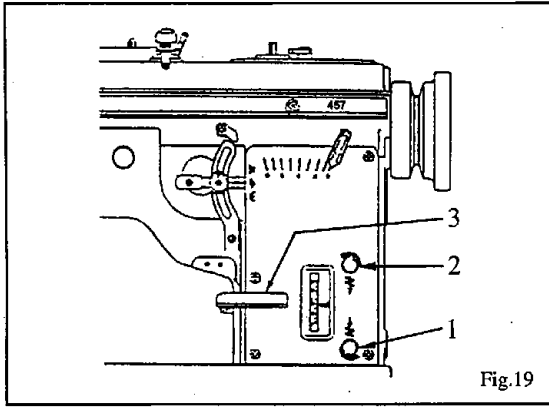

Fig.19

To regulate stitch length for forward feed, turn stitch length regulating screw stud (1), Fig.19, clockwise to shorten the stitch length and counterclockwise to lengthen the stitch length.

To regulate stitch length for reverse feed, turn stitch length regulating screw stud (2), Fig.19, clockwise to shorten the stitch length and counterclockwise to lengthen the stitch length.

To change the direction of feed for back tacking, depress feed reverse lever (3) quickly to lowest position and hold lever (3) in this position until back tack is completed. The machine will return to forward feed when lever (3) is released.

SELECTING THE NEEDLE POSITION

(457A 105/125/135)

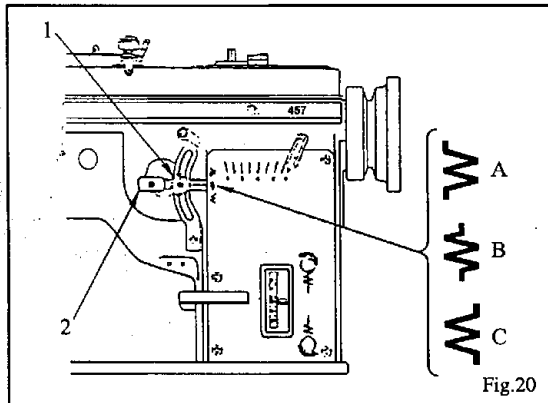

Fig.20

To select desired needle position, loosen thumb nut (1) and move lever (2) to desired needle position & tighten thumb nut.

- A...Left needle position
- B...Center needle position
- C...Right needle position

SETTING THE STITCH WIDTH

(457A 105/125/135)

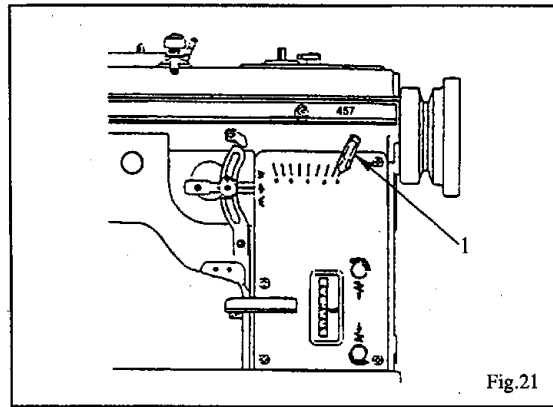

Fig.21

The width of zigzag stitch is regulated with lever (1), Fig.21

457A 125..... 0~5mm
457A 105/135..... 0~8mm

SETTING THE STITCH WIDTH

(457A 143)

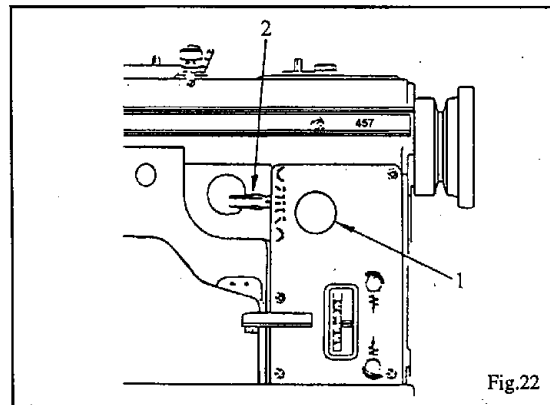

Fig.22

To regulate the width of zigzag stitch, loosen thumb screw (1), Fig.22, and set lever (2) to desired setting.

REGULATING THE AMOUNT OF OIL FLOW TO SEWING HOOK

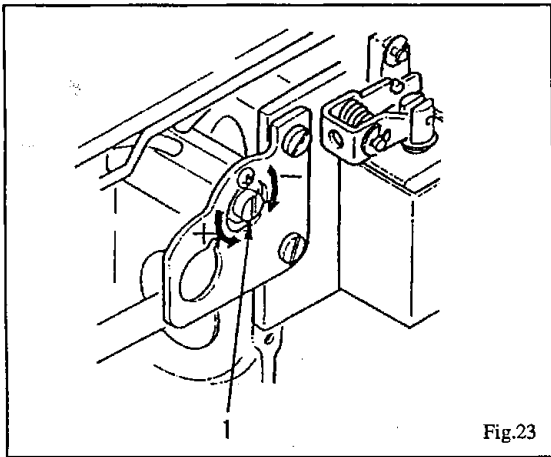

Fig.23

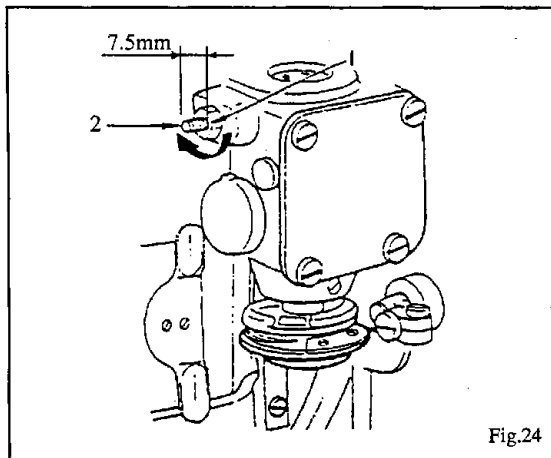
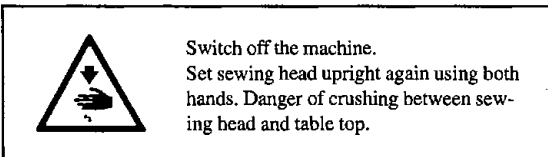

Fig.24



To regulate the amount of oil flow to sewing hook, tip machine back on its hinges, loosen nut (1) and turn oil flow regulating screw (2) as shown in Fig.23.

To increase the amount of oil flow, turn screw (2) clockwise.
To increase the amount of oil flow, turn screw (2) counterclockwise.

NOTE: If oil supply to sewing hook is still not sufficient even when oil flow regulating valve (1) is adjusted to maximum, loosen nut (1), Fig. 24 and turn oil flow regulating screw (2) in the direction of arrow (A).
(Oil flow regulating screw (2) is adjusted to approximately 7.5mm when machine leaves the factory.)

INSTALLING THE BELT GUARD

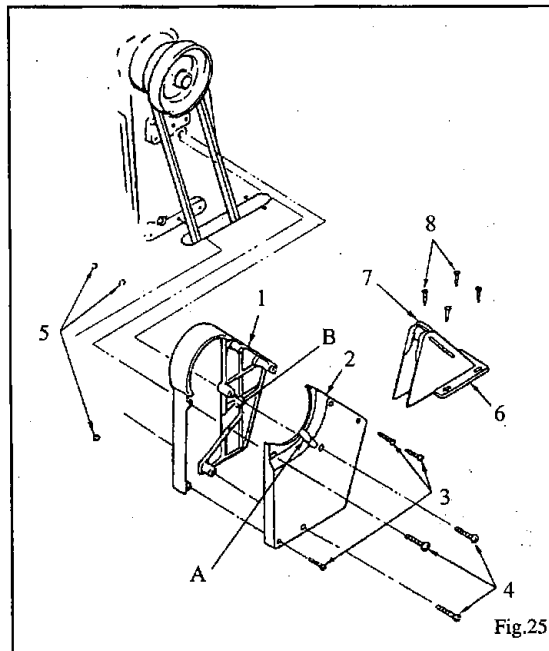
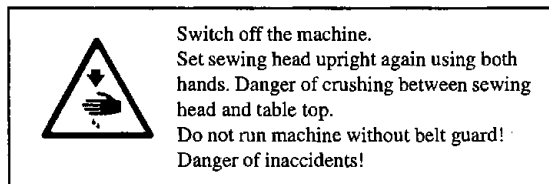

Fig.25



Above table surface

Fasten belt guards (1) and (2) to machine head with belt guard screws (3) and (4) and also with nuts (5) as shown in Fig.24. Then fasten belt guard (6) to table with wood screws (8) making sure it will not interfere with belt guard (1) and (2), and so that the V-belt will rest against the belt guard slide (7) when machine is tipped back on its hinges.

When installing belt guard for machines with thread trimmer, remove portion "A" from belt guard (2).

When installing belt guard for machines with touch back system remove portion "A" and "B" from belt guard (1) and (2).

Below table surface

Install belt guard so that motor pulley and V-belt will rotate freely without interference.

SPECIFICATIONS

Stitch type : see table page 8

Variety : see table page 8

Machine pulv : 74mm effective dia. for V-belt

Needle catalog No. : see table page 8

Needle size : see table page 8

Fabric clearance : 6.2mm

Workspace width : 280mm

Workspace height : 120mm

Bed dimensions : 477x178mm

Max. stitch length : see table page 8

Max. sewing speed : see table page 8

Subject to alterations in design and dimensions.



MACHINE CARE



Switch off the machine.
Set sewing head upright again using both hands. Danger of crushing between sewing head and table top.

When the machine is in regular use, remove the lint and dust from around sewing hook area once a day.

A machine in frequent use should be cleaned and oiled more frequently.

Max. sewing speed					
Variety	Stitch type	Max. sewing speed in s. p. m ▲	Max. needle bight	Max. stitch length	Needle catalog No. (Needle system)
105L	 304 (zigzag lockstitch)	5,000	8.0 mm	1.3 mm	1906-07
105M				20 SPI	(135X53 M Ball)
125L			5.0 mm	5.1 mm	1906-01
125M	5 SPI			(135X53)	
135L	 321 (3 step zigzag)		8.0 mm	2.0 mm	1906-07
135M				13 SPI	(135X53 M Ball)
143L	 scallop stitch	4,200		4.2 mm	1906-01
143M			6 SPI	(135X53)	
			1.3 mm	1906-07	
	20 SPI		(135X53 M Ball)		
	2.5 mm		1906-01		
	10 SPI		(135X53)		

▲ Depending on material and operation.

