

Exciting products from SINGER

Electric Portable Typewriter combines professional office electric and personal portable features. Uniform, crisp print on originals; clean, clear carbons . . . as many as ten copies.

FEATHERWEIGHT* portable sewing machine weighs only eleven pounds; travels and stores easily. A compact, quiet, smooth-running traveling friend.

Personal Portable Television performs perfectly indoors, outdoors, anywhere. Plug-in or battery-operated. Carrying case, sun visor and earphone included. Battery pack available at moderate extra charge. VHF and UHF.

At your local SINGER CENTER there are lots more you should see, too!

THE SINGER COMPANY

Sewing Machines

Fabrics

Stereo Phonographs

TV Sets

Typewriters

Floor-Care Products

*A Trademark of THE SINGER COMPANY

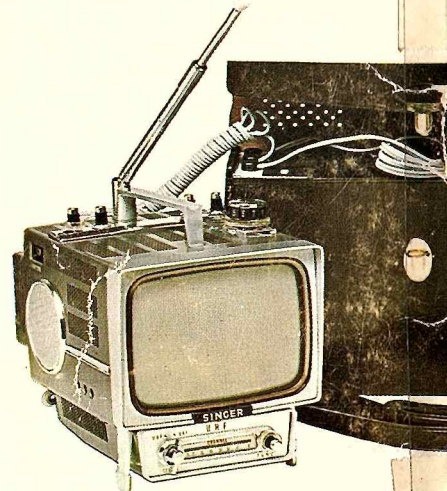

Instructions

Style-Mate*

STANDARD ZIG-ZAG SEWING MACHINE BY **SINGER**
MODEL 347

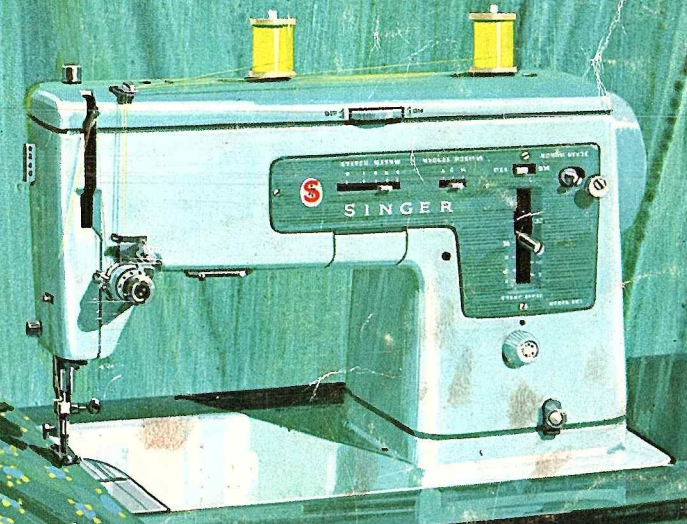

What's new for tomorrow is at **SINGER** today!*

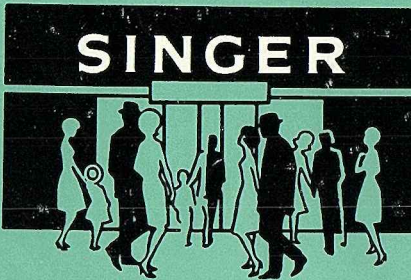

Congratulations!

As the owner of the *Style-Mate** Standard Zig-zag Sewing Machine by SINGER, you are about to enter a wonderful new world of sewing! From the moment you begin to sew on your *Style-Mate* Model 347, you will be delighted with its easy, dependable operation.

- Perfect straight stitching.
- Timesaving blindstitching.
- Practical and decorative zig-zag stitching.
- Two-needle stitching for those extra finishing touches.

May we recommend that, before you begin to sew, you discover all the many advantages of your Model 347 by going through this instruction book step by step while seated at your machine.

SINGER* service is always close at hand. If your sewing machine should need servicing, call your local SINGER CENTER to be sure of warranted SINGER parts and service. You will find the address under THE SINGER COMPANY in the telephone directory.

SINGER GUARANTEE

WE GUARANTEE that each SINGER* sewing machine has been carefully manufactured and is in perfect operating condition on delivery. When subject to normal family use and care, any parts requiring replacement at any time owing to defects in material or workmanship will be replaced without charge.

THIS GUARANTEE does not apply to parts requiring replacement owing to natural wear or to abuse or negligence of the user or in the event the machine is serviced by other than a SINGER representative or Approved Dealer or with parts other than those supplied by The Singer Company.

IN ADDITION to the above guarantee of parts, each machine will be inspected and adjusted whenever necessary without charge for labor for a period of one year from date of purchase.

THIS GUARANTEE is effective only with respect to the person making the purchase from The Singer Company or one of its Approved Dealers. The original Sales Agreement, or Cash Receipt, must be presented to obtain the benefits of the guarantee.

AGREEMENTS inconsistent with the foregoing shall be void and of no effect.

THE SINGER COMPANY

INDEX

	Page		Page
Applique	38	Principal Parts	2
Blindstitch Hems	31	Reverse Stitching	14, 18
Bobbin	5, 6	Script Lettering	42
Winding	6	Seams, How to Sew	18
Bobbin Case	47	Curved	26
Threading	8	Finishes	30
Buttonholes	35	Flat Felled	29
Buttons	34	Knit Fabric	28
Check List	52	Lingerie	27
Cleaning	46	Straight	26
Darning	44	Shell Edging	32
Darts	33	Slide Plate	3, 51
Electrical Controller	5	Spool Pin	3
Embroidery	40	Stitch Length	14, 22
Fabric, Needle, Thread and		Stitch Length Selector	4, 14
Stitch Length Table	13	Stitch Width	11, 21
Face Plate	48	Stitch Width Selector	4, 11
<i>Fashion Aids</i>	53	Stop-Motion Screw	5
Feed Dog	3	Straight Stitching	11
Free-Motion Stitching	41	Adjusting for Fabric	12
Guiding and Supporting Fabric	19	Needle Position	11
Hand Wheel	3	Take-up Lever	3
Light Bulb	51	Tension Adjustment	3, 5
Lubrication	46	For Straight Stitching	16
Mending	43	For Zig-Zag Stitching	22
Needle	12	Thread	13
Replacement	12	Thread Cutter	3
Threading	9	Threading the Machine	6
Needle Position Selector	4, 11, 21	Throat Plate	2
On-Off Switch	3	Changing	47
Pattern Selector	21	Lifter	5, 40
Pin Basting	25	Top Stitching	32
Presser Foot	2	Two-Needle Stitching	23
Changing	40	Zig-Zag Stitching	21
Presser Foot Lifter	3	Needle Position	21
Pressure Adjustment	3, 15	Stitch Width	21
Pressure Gauge	3		

CONTENTS

	Page
1. Getting to Know Your Sewing Machine	2
Principal Parts	2
2. How to Thread Your Sewing Machine	6
The Bobbin Thread	6
The Needle Thread	9
Raising the Bobbin Thread	10
3. Straight Stitching	11
How to Position the Needle	11
How to Adjust for Your Fabric	12
How to Sew a Seam	18
4. Zig-Zag Stitching	21
How to Set Pattern Selector	21
How to Set Stitch Width and Needle Position	21
How to Set Stitch Length and Needle Thread Tension ..	22
5. Two-needle Stitching	23
How to Set the Machine	23
How to Insert Second Needle	24
How to Thread the Machine	24
6. Clothes and Home Decorations	25
Seams	25
Blindstitch Hems	31
Top Stitching	32
Shell Edging	32
Darts	33
Buttons	34
Buttonholes	35
Applique	38
Embroidery	40
Script Lettering	42
Mending	43
Darning	44
7. Caring for Your Sewing Machine	46
Every Week or So	46
Every Few Months	49
To Change the Light Bulb	51
To Replace the Slide Plate	51
Performance Check List	52
<i>Fashion* Aids</i>	53

1. Getting to know your sewing machine

PRINCIPAL PARTS

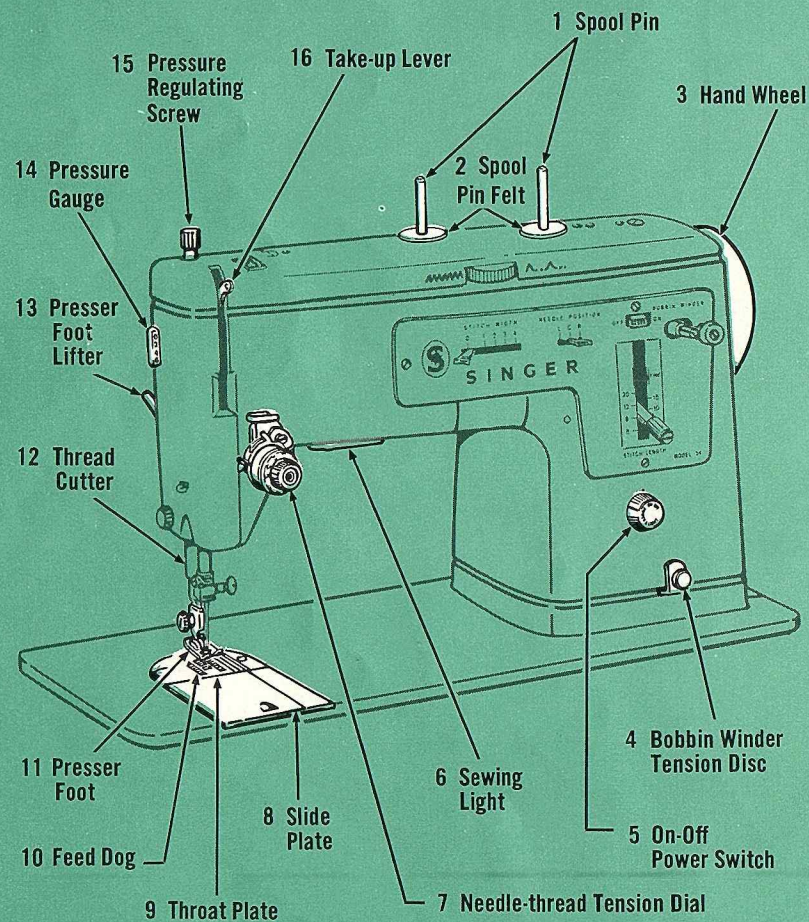

Button Foot #161613

This short, open foot holds any two-hole or four-hole button securely for stitching. The groove in the foot can be used to hold a needle, over which a thread shank can be formed.



Seam Guide #161172

The Seam Guide helps keep seam width uniform when extra control is needed, especially on unusually wide or narrow seams. Used as a guide for top stitching and blindstitch hemming.



Leather and Suede Needle Catalog 2032 (15x2)

This needle is recommended whenever you stitch leather or suede. Its slim wedge point pierces skins cleanly to ensure a neat, uniform stitch. Use it in place of the Catalog 2020 (15x1) needle. Available in sizes 11, 14 and 16.



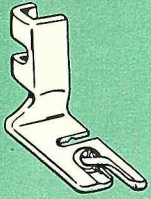

Hemmer Foot #161671

Using the Hemmer Foot, you can turn and stitch a hem in a single operation. Thus, you can eliminate basting or pinning whenever you are making narrow hems, ruffle edges, lingerie finishes, hemmed seams and the like.

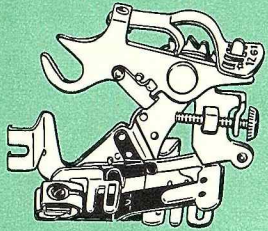

Ruffler #86742

The Ruffler offers a simple effective way to make gathered and pleated ruffles. Ruffles may be made separately or made and applied in one operation.

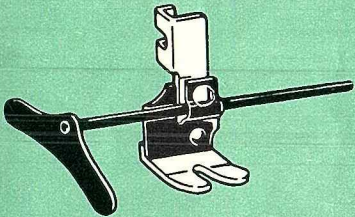

Quilter #35932

The Quilter is excellent for the placement of stitching in block, floral or scroll designs, is especially well adapted to stitching lightly padded materials. The short open foot permits following curved lines with ease and accuracy; the adjustable space guide placed to the right or left of the needle keeps rows of stitching parallel.

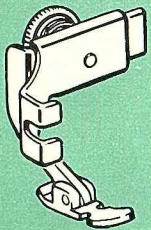

Zipper Foot #161127

This foot makes it easy to place stitching close to a raised edge. Thus, it is useful for corded seams and zipper insertions. The hinged foot easily rides over pins, heavy layers of fabric, or across seams.

... And What They Do

- 1 **Spool Pin** — Holds thread spools of various sizes.
- 2 **Spool Pin Felt** — Helps thread unwind smoothly.
- 3 **Hand Wheel** — Controls movement of take-up lever and needle. Always turn it *toward you*.
- 4 **Bobbin Winder Tension Disc** — Regulates thread tension for bobbin winding.
- 5 **On-Off Power Switch** — Turns on the power and the sewing light simultaneously. When machine is not in use, the switch should be in OFF position.
- 6 **Sewing Light** — Pours light on sewing area.
- 7 **Needle-thread Tension Dial** — Numbers allow for exact, easy-to-duplicate tension settings.
- 8 **Slide Plate** — Opens easily for removal and replacement of bobbin.
- 9 **Throat Plate** — Numbered guidelines help you keep seams straight.
- 10 **Feed Dog** — Feeds fabric as it is being stitched.
- 11 **Presser Foot** — Holds fabric against feed dog.
- 12 **Thread Cutter** — Cuts thread conveniently and safely.
- 13 **Presser Foot Lifter** — At back of machine, raises and lowers presser foot.
- 14 **Pressure Gauge** — Numbers eliminate guesswork when duplicating settings.
- 15 **Pressure Regulating Screw** — Regulates degree of pressure exerted on fabric by presser foot.
- 16 **Take-up Lever** — Controls needle thread.

17 Bobbin Winder Switch and Spindle — Lets you fill the bobbin with thread quickly and easily. Bobbin stops winding when full.

18 Needle Position Selector — Places the needle in either left, center or right stitching position. CENTER position is used most often. LEFT and RIGHT settings are for special stitch placement.

19 Pattern Selector — Lets you select plain zig-zag (WWWWWW) stitching or blindstitching (Λ...Λ...).

20 Stitch Width Selector — Settings 1 through 4 allow for a variety of zig-zag stitch widths. Setting 0 is for straight stitching.

21 Stitch Length Selector — Lets you stitch forward and in reverse. Numbers indicate number of stitches per inch; FINE area is for closed zig-zag stitching.

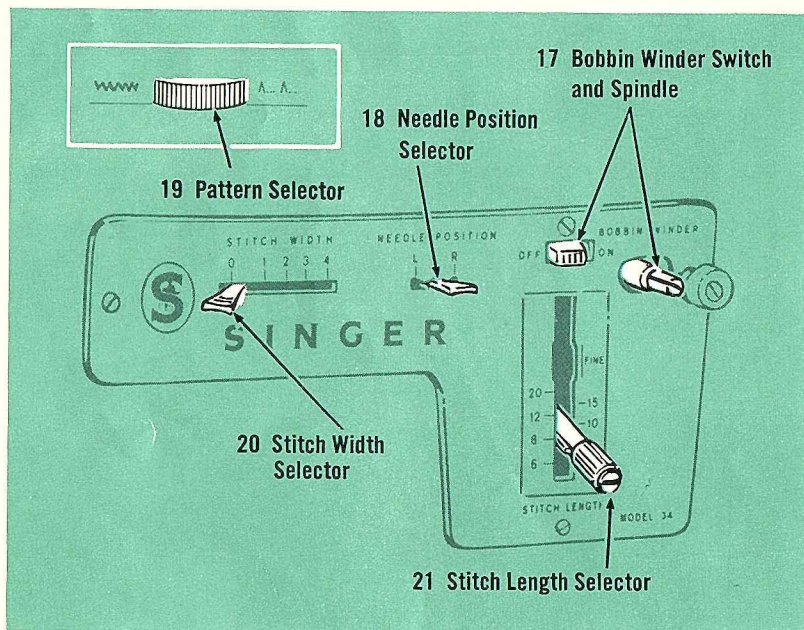

FASHION* AIDS AVAILABLE FOR PURCHASE

Among the many *Fashion Aids* that will fit your *Style-Mate* sewing machine are those described below. These are available at your local Singer Center. These aids will increase the versatility of your machine and enable you to give your sewing that extra professional designer touch.

Professional* Buttonholer #86721

The *Professional Buttonholer* enables you to make a buttonhole in a fraction of the time required by other methods. You choose the style and the size, and the buttonholer guides the fabric to make either straight or eyelet-end buttonholes. It will also make eyelets for studs and lacings.

Edge Stitcher #36865

The *Edge Stitcher* regulates the placement of straight stitching close to a fabric edge by means of a series of slotted guides.

Gathering Foot #161659

The *Gathering Foot* is designed to ensure evenly spaced shirring with "locked-in" fullness.

Special Purpose Foot #161455

This light, flexible foot is designed for zig-zag satin stitching, buttonholing and applique. The raised center section allows closely spaced zig-zag stitches to feed smoothly and evenly. The small eyelets at the front of the foot hold filler cord when desired.

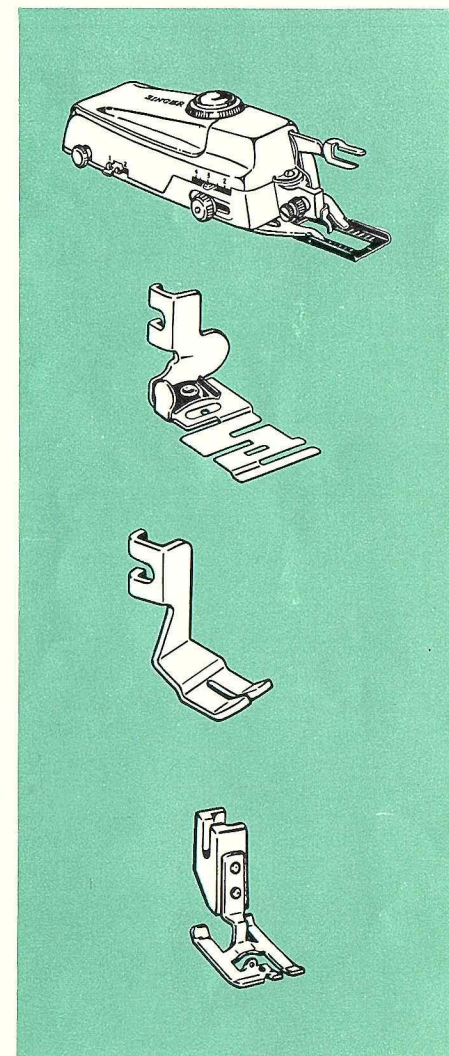

PERFORMANCE CHECK LIST

If Machine Fails to Start:

- Are electrical plugs properly connected?
- Is Power and Light Switch on?

If Thread Breaks:

- Is machine properly threaded?
- Is needle the correct size for the thread and fabric you are using?
Is a Catalog 2020 (15x1) needle correctly inserted and securely tightened in the needle clamp?
- Is thread free of slubs and knots?
- Is needle-thread tension too tight?
- Are thread guides, tension discs and bobbin area lint-free?

If Fabric Fails to Feed:

- Is presser foot down?
- Is pressure adjusted properly for the weight and texture of your fabric?
- Is Stitch Length Selector properly set?

Remember To:

Set Stitch Width Selector on 0 before you rotate Pattern Selector dial.

Refer to your Instruction Book. It was written to explain the most efficient way to operate and use this versatile new machine.

Keep your machine in good working condition by following the easy at-home-care steps outlined in the Instruction Book.

Enjoy sewing! If you have any questions, please write to:

Department of Sewing Education
The Singer Company
30 Rockefeller Plaza, New York, N. Y. 10020

22 Throat Plate Lifter — Raises the throat plate to prevent the feed dog from moving the fabric. Use it for button sewing, free-motion darning and embroidery.

23 Plug — Before plugging in the machine, be sure that the voltage and number of cycles stamped on the plate under the hand wheel are within the range marked on the electric meter installed by your power company. To connect the machine, push the machine terminal plug into the receptacle at the right end of the machine. Then insert the wall plug into an electrical outlet.

24 Electrical Speed Controller — Controls speed of the machine; the harder you press, the faster it will sew.

25 Transparent Bobbin — Shows thread supply; is easily removed for bobbin winding.

26 Bobbin-thread Tension Screw — Seldom needs adjustment. A very slight turn produces a noticeable change in tension.

27 Stop-motion Screw — Directs power to the needle. Loosen the screw for bobbin winding.

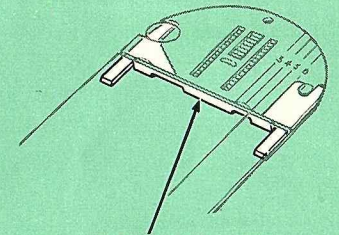

22 Throat Plate Lifter

23 Machine Terminal Plug

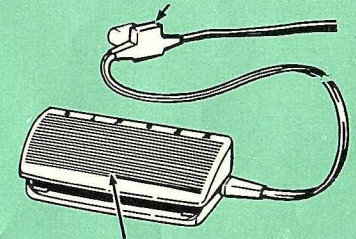

24 Electrical Speed Controller

25 Transparent Bobbin

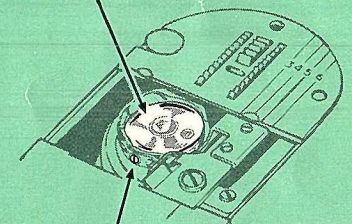

26 Bobbin-thread Tension Screw

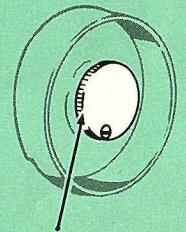

27 Stop-motion Screw

2. How to thread your sewing machine

Like all sewing machines that produce what is called a "lockstitch", your *Style-Mate* sewing machine sews with two threads. The upper thread comes from the spool and is threaded through the eye of the needle. The lower thread comes from the bobbin, the small plastic spool that you wind using the machine. It is best to wind the bobbin before threading the needle.

THE BOBBIN THREAD

To Wind the Bobbin

1. Turn hand wheel toward you until needle is at its highest position.
2. Open the slide plate and lift out bobbin.
3. Loosen the needle stop-motion screw with your right hand while holding the hand wheel with the left.
4. Place bobbin on spindle.

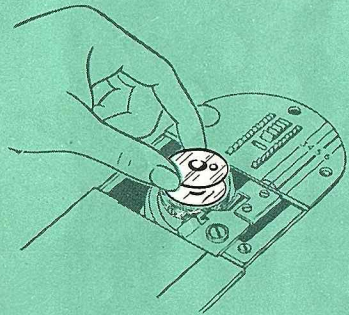

Removing Bobbin

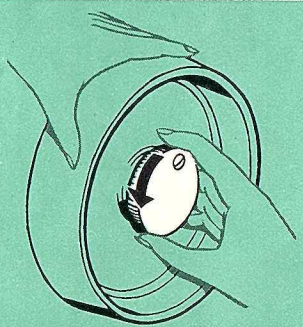

Loosening Stop-Motion Screw

TO CHANGE THE LIGHT BULB

Be sure power and light switch is in "OFF" position.

To Remove Bulb:

With thumb and forefinger of right hand, push in and down on tab of light lens and lower the light bracket. Do not attempt to unscrew bulb. Press it up into socket and at same time turn bulb over in direction shown to unlock bulb pin.

To Replace Bulb:

Press new bulb into socket, with bulb pin entering slot of socket and turn it over in direction shown to lock bulb in position. Release bracket, and entire assembly will snap back into recess.

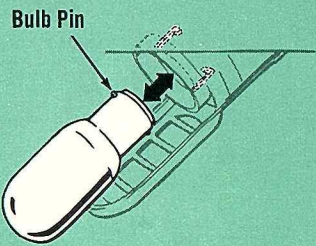
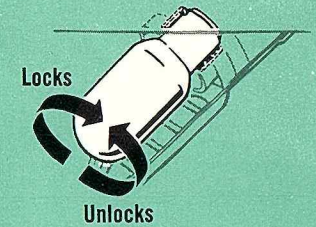

TO REPLACE SLIDE PLATE

You will not have any occasion to remove the slide plate. However, if it should accidentally become disengaged from the machine, it is easily replaced.

- Raise the presser foot and the needle.
- Place slide plate in slide way with the front edge close to, but not covering the retaining spring (as shown).
- With a screwdriver, lift each end of the spring into each of the side grooves on the underside of the plate.
- Draw the plate gently toward you and fully engage the spring.
- Close slide plate.

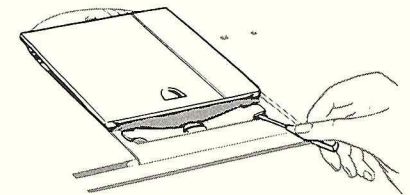

Lubricate parts under the bottom cover.

- Be sure machine is disconnected from electrical supply.
- Tilt machine back and remove retaining nut from threaded stud A, being careful not to lose felt washer, and remove cover from underside of machine.
- Oil each of the places indicated by arrows. Avoid getting oil on any part of the motor or hook driving belt.
- Replace bottom cover, felt washer and retaining nut. Tighten retaining nut with screwdriver.

Motor Requires No Lubrication

IF THE MACHINE IS TO BE STORED

It is necessary to protect the machine from rust damage. Before storing, give the machine a thorough brush-cleaning to remove all traces of lint and fluff. Follow by swabbing all exposed parts with a lint brush saturated with SINGER oil.

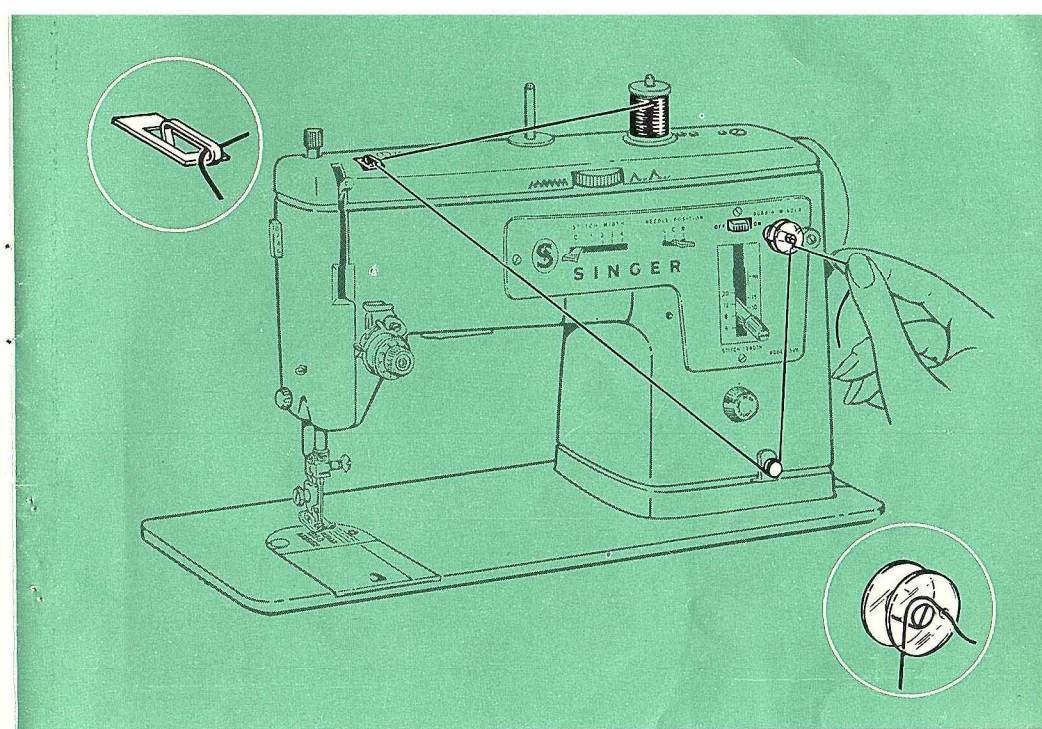
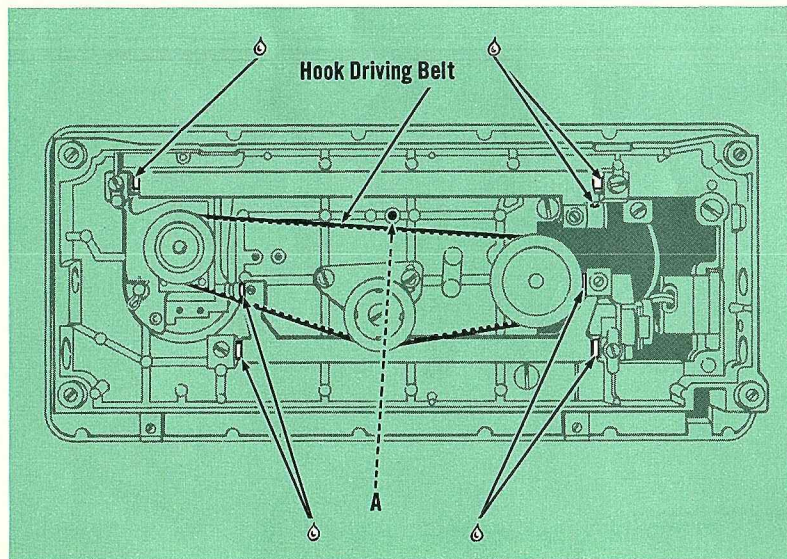

5. Place spool of thread on spool pin over the spool pin felt and lead thread through eyelet, and around tension disc.
6. Pass thread, from the inside, through hole in bobbin.
7. Move bobbin winder switch to ON position, hold thread end as shown and start the machine.
8. Cut off thread end after a few coils have been wound on the bobbin.
9. When required amount of thread has been wound (winding will stop when bobbin is full), move bobbin winder switch to OFF position, and cut thread.
10. Tighten stop-motion screw by turning it away from you with right hand, while holding the hand wheel with the left hand.

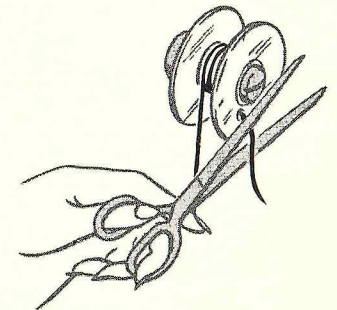
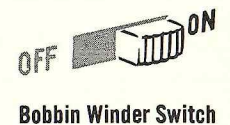

To Thread the Bobbin Case

1. Hold bobbin so that thread unwinds in direction shown, and insert bobbin in bobbin case.

2. Pull thread into notch, draw it under tension spring, and into slot.

3. Draw about 3 inches of thread diagonally across the bobbin.

4. Close slide plate with the thread in slot between the throat plate and slide plate.

EVERY FEW MONTHS

Oil and lubricate parts under the arm cover.

- Disconnect machine from electricity supply.
- Apply a drop of oil to each place indicated.
- Remove screws A; lift off arm cover.
- Apply a small amount of lubricant to gears as shown. **Never apply Oil to Gears.**
- Replace arm cover.

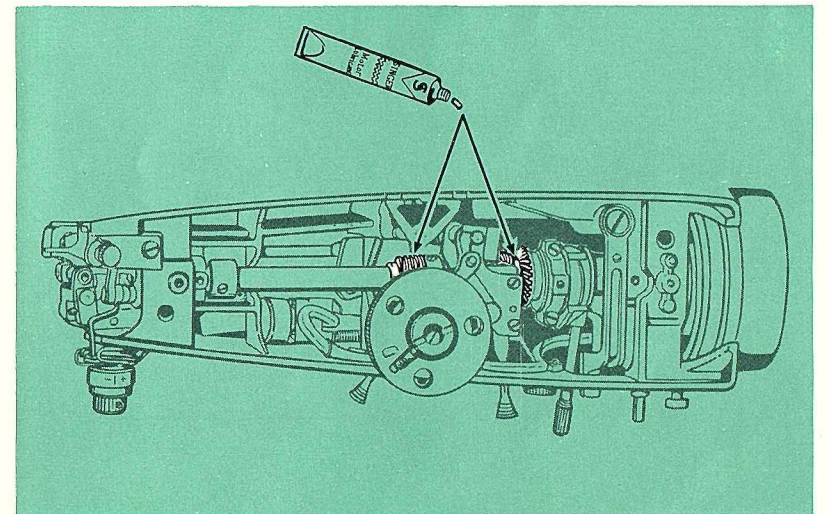
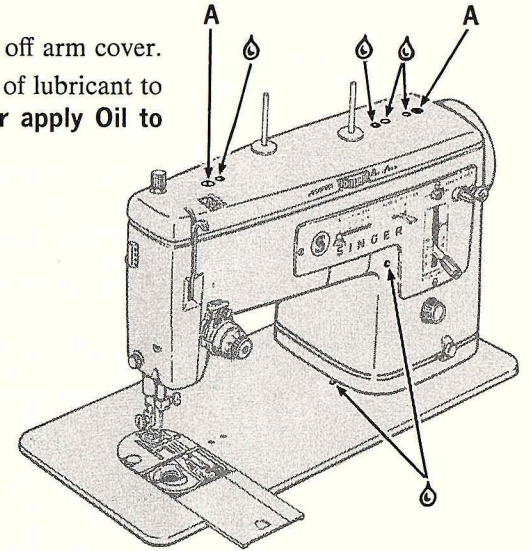

To Remove Face Plate

- Turn pressure regulating screw down until pressure pointer is between 4 and 6.
- Loosen and remove thumb screw and remove face plate by sliding it downward.

To Replace Face Plate

- Center top of pressure gauge in face plate over pressure pointer on machine.
- With pointer in gauge slot, slide face plate up so that retaining tab at top of plate is engaged under edge of arm top cover.
- Align screw hole at lower edge of plate with screw hole in machine and replace and tighten thumb screw.
- Re-set pressure.

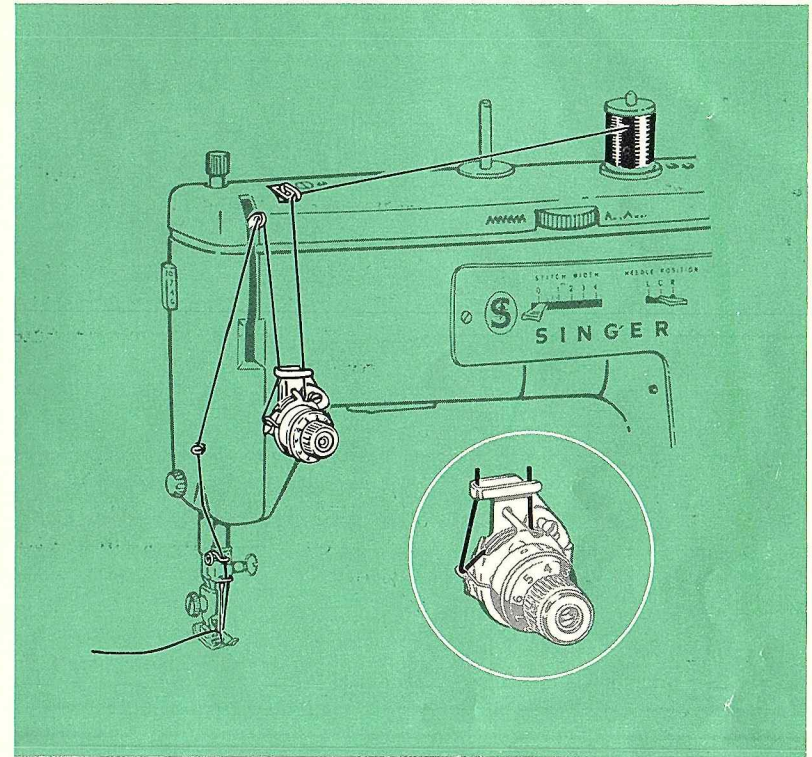
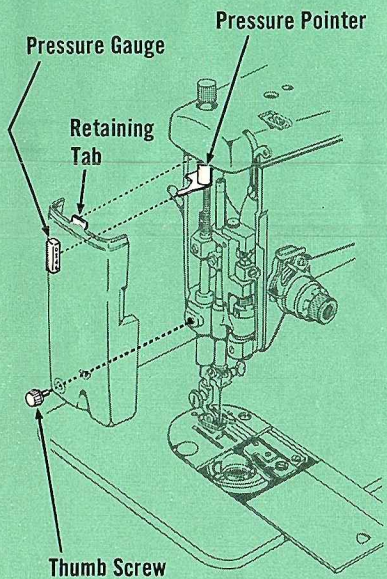

THE NEEDLE THREAD

1. Turn hand wheel toward you to raise needle to its highest position.
2. Make sure spool pin felt is around spool pin at top of machine.
3. Place spool of thread on spool pin and lead thread through threading points shown. Thread the needle from front to back.
4. Draw about 3 inches of thread through eye of needle.

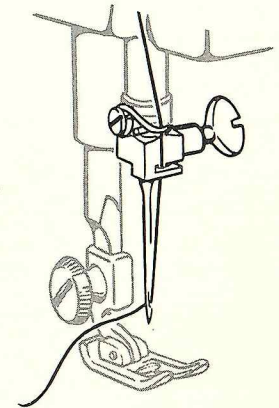

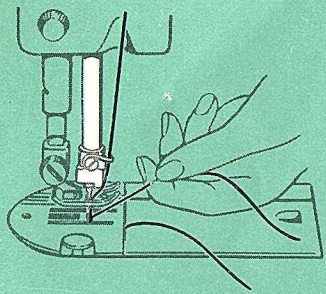

RAISING THE BOBBIN THREAD

Now that you have wound the bobbin and threaded the needle, you will need to raise the bobbin thread through the needle hole in the throat plate.

1. Hold needle thread lightly with left hand and turn hand wheel slowly toward you so that needle enters throat plate.
2. Continue turning hand wheel and holding needle thread until needle rises and brings up bobbin thread in a loop.
3. Undo the loop with your finger.
4. Place both needle and bobbin threads under presser foot, and lay them diagonally across the feed dog.

... You are now ready to sew

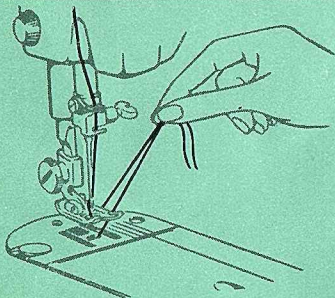
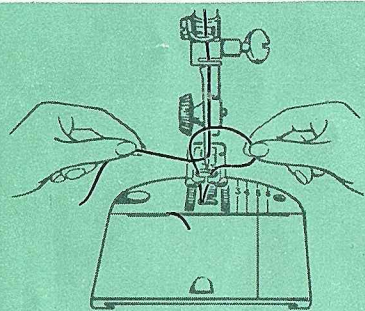
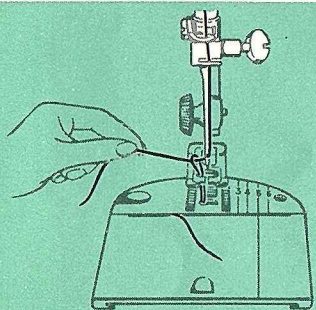

To Remove and Replace Bobbin Case

- Open slide plate, raise needle, place thumb under right side of throat plate and lift up to remove throat plate.
- Lift and push holder to right, as shown, and remove bobbin case.
- Remove all lint and fluff.
- Replace bobbin case — groove under tension spring fits on hook raceway and fork of case straddles positioning stud under feed dog.
- Push holder to left until it snaps into position.
- Replace throat plate under clamping pin, push to left, and press down until it snaps into place.

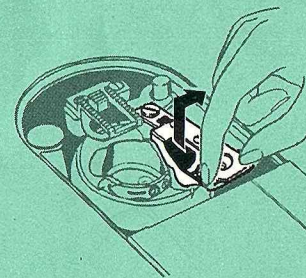

Positioning Stud

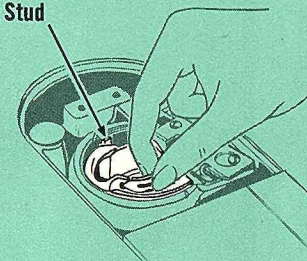

7. Caring for your sewing machine

Your sewing machine is a fine yet sturdy precision instrument, and it will serve you perfectly for many years if you take a few simple steps to keep it in good condition. How often you will need to clean, oil and lubricate the machine will depend on how often you use it and where you keep it. The following general guidelines assume that you will be sewing two or three times a week. But if you use the machine continuously, clean and oil it daily. Or, if you keep it in a very warm or damp place, oil and lubricate it more frequently than the guidelines suggest.

EVERY WEEK OR SO

Remove lint and fluff from exposed parts. (As a matter of fact, you will be able to see the lint and fluff gathering on these parts, and we recommend that you remove them as they accumulate.)

With a soft cloth, clean:

- Tension discs
- Take-up lever and thread guides
- Presser bar and needle bar
- Machine surface (arm and bed)

If necessary, dampen the cloth to clean the machine surface. *Do not use detergents.*

With a lint brush, clean:

- Behind face plate
- Bobbin area (For instructions on removing bobbin case, see next page.)

After each cleaning, apply a drop (but no more than a drop) of SINGER* oil to the areas shown. Then sew a line of stitching on a scrap of material to remove excess oil.

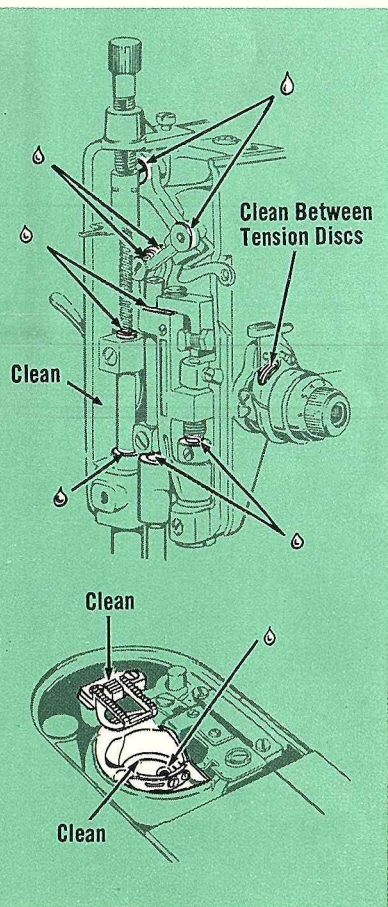

3. Straight stitching

Stitch Width: **O**

Needle Position: **C**

HOW TO POSITION THE NEEDLE

Before you set your *Style-Mate* sewing machine for any kind of stitching, turn the hand wheel toward you until the needle is above the throat plate. Then, to set for straight stitching, simply move the Stitch Width Selector to O position and the Needle Position Selector to center (C) position. These settings locate your needle and control its movement so that it stitches straight up and down in the center of the needle hole with no sidewise movement. When alternating between straight stitching and zig-zag stitching, set the Pattern Selector at (WWWWWW). See page 21 for zig-zag stitch adjustment.

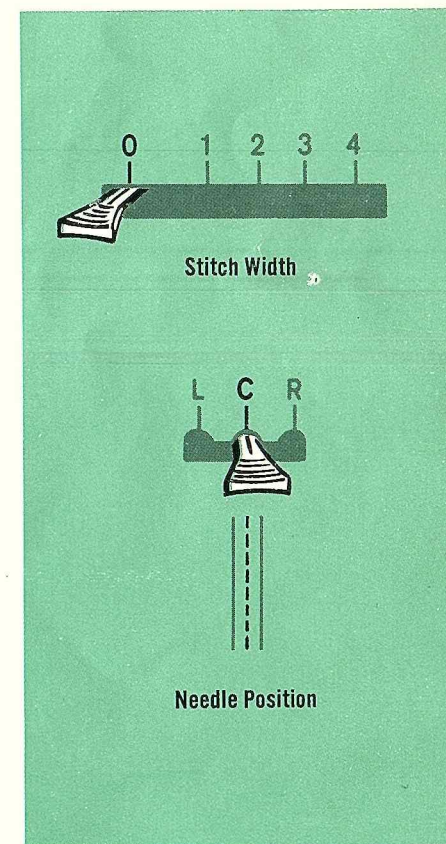

HOW TO ADJUST FOR YOUR FABRIC

As you get ready to sew, take advantage of the flexibility of your sewing machine. With a choice of needle sizes and three easy-to-use selectors for stitch length, pressure, and needle-thread tension, you can adjust the machine to sew perfectly on a wide variety of fabrics. The table on page 13 will guide you in selecting the correct thread and needle sizes and stitch length according to the weight of your fabric.

Changing the Needle

1. Turn hand wheel over toward you until needle is at highest position.
2. Loosen needle-clamp screw and remove needle.
3. Insert new needle in clamp with the flat side of the needle to the back, and the *long groove toward you*; push it up as far as it will go.
4. Tighten needle clamp screw.

This machine uses needle Catalog 2020 (15X1), available in sizes 9, 11, 14, 16 and 18.

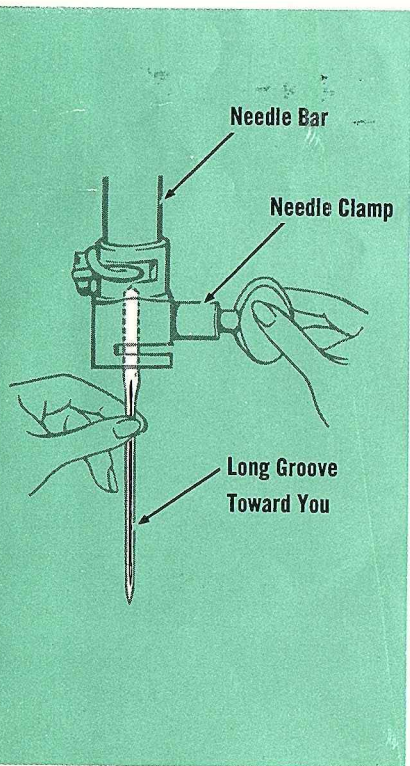

Darning With Embroidery Hoop

Stitch Width: **0**
Needle Position: **C**
Stitch Length: **FINE** (above 20)
Presser Foot: None
Throat Plate Lifter *under* Throat Plate

1. Trim ragged edges from area to be darned.
2. Center worn section in embroidery hoop.
3. Position work under needle and lower presser bar to engage tension.
4. Hold needle thread loosely with left hand, turn hand wheel over and draw bobbin thread up through fabric. Hold both thread ends and lower needle into fabric.
5. Outline area to be darned with running stitches for reinforcement.
6. Stitch across opening, moving hoop under needle at a slight angle from lower left to upper right. Keep lines of stitching closely spaced and even in length.
7. When opening is filled, cover area with crosswise lines of stitching.

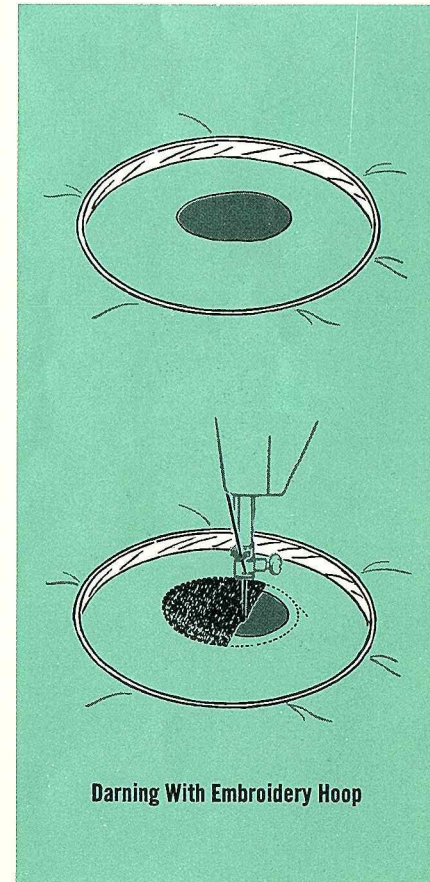

Darning With Embroidery Hoop

DARNING

You may choose to darn either with or without an embroidery hoop. When greater control is needed, free-motion stitching with an embroidery hoop is usually best.

Darning Without Embroidery Hoop

Stitch Width: **0**
 Needle Position: **C**
 Stitch Length: **FINE** (above 20)
 Pressure Dial: **0**
 Throat Plate Lifter *under* Throat Plate

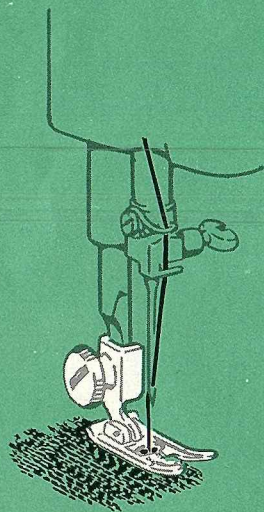

Darning Without Embroidery Hoop

1. If area to be darned is open, baste an underlay in place.
2. Place area to be darned under presser foot.
3. Lower presser foot and start stitching, alternately drawing fabric toward you and pulling it gently away from you.
4. Continue this forward and backward motion as you fill the area with parallel lines of stitching.
5. For additional strength, cover area with crosswise lines of stitching.

FABRIC, NEEDLE, THREAD, AND STITCH LENGTH TABLE

FABRICS	THREAD SIZES	NEEDLE SIZES (CAT. 2020)	STITCH LENGTH SETTING
DELICATE —tulle, chiffon, fine lace, silk, organdy	Fine Mercerized, 100 to 150 Cotton, Synthetic Thread	9	15 to 20
LIGHTWEIGHT — batiste, organdy, jersey, voile, taffeta, silk, crepe, chiffon velvet, plastic film	50 Mercerized, 80 to 100 Cotton, "A" Silk, Synthetic Thread	11	12 to 15 (8 to 10 for plastic)
MEDIUM WEIGHT — gingham, percale, pique, linen, chintz, faille, satin, fine corduroy, velvet, suitings, stretch fabric	50 Mercerized, 60 to 80 Cotton, "A" Silk, Synthetic Thread	14	12 to 15
MEDIUM HEAVY — gabardine, tweed, sailcloth, denim, coatings, drapery fabrics	Heavy Duty Mercerized, 40 to 60 Cotton	16	10 to 12
HEAVY — overcoatings, dungaree, upholstery fabrics, canvas	Heavy Duty Mercerized, 20 to 40 Cotton	18	6 to 10

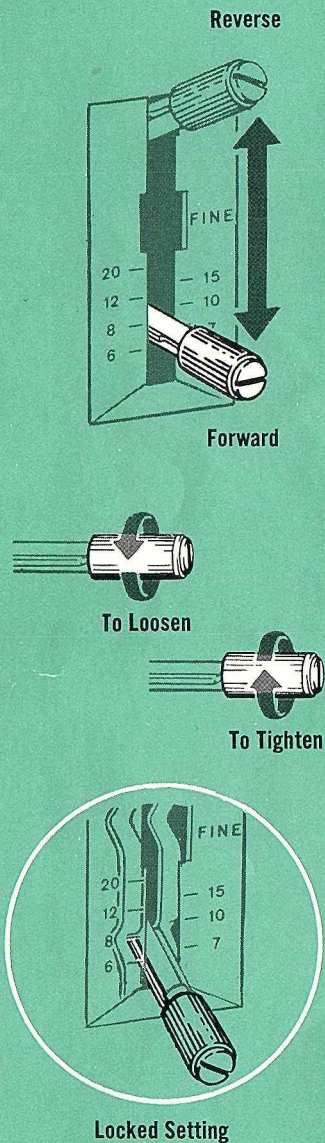

Adjusting Stitch Length

The Stitch Length Selector does two jobs: it controls the number of stitches per inch, and it lets you sew either forward or in reverse.

The numbers on either side of the selector represent the number of stitches per inch: *the higher the number, the shorter the stitch.* As the Stitch Length Selector is moved up in the FINE area, stitch length diminishes to the vanishing point. The FINE area is used for closed zig-zag stitching only. Generally, shorter stitches are best for lightweight fabric; longer ones for heavy fabric.

To Set Stitch Length

- Loosen thumb nut by turning to left.
- Position lever for desired stitch length.
- Tighten thumb nut by turning to right.

For reverse stitching, simply raise the selector as far as it will go. Do not loosen the thumb nut to reverse unless you are using the No. 6 setting, in the very bottom position.

MENDING

The plain zig-zag stitch pattern is just as useful for mending as it is for creative sewing. The zig-zag stitch forms a firm, flexible bond for repairing tears and for reinforcing elastic.

Tears

Pattern Selector: W W W W W W W

Stitch Width: 2-4

Needle Position: C

1. Trim ragged edges.
2. Place underlay on the wrong side of tear for reinforcement. (It is best not to baste or pin the underlay, since you will be bringing the edges of the tear together in the next step.)
3. Stitch on the right side, bringing the edges of the tear together.
4. Shorten stitch length at ends and corners to give extra strength.
5. Trim underlay.

Elastic

1. Use the same settings as for "Tears" above.
2. Hold the elastic taut as you stitch so that it will remain stretchable after stitching is completed.

Bar Tacks

Use a closed zig-zag stitch to bar-tack garters, pockets, zippers, shoulder straps, etc.

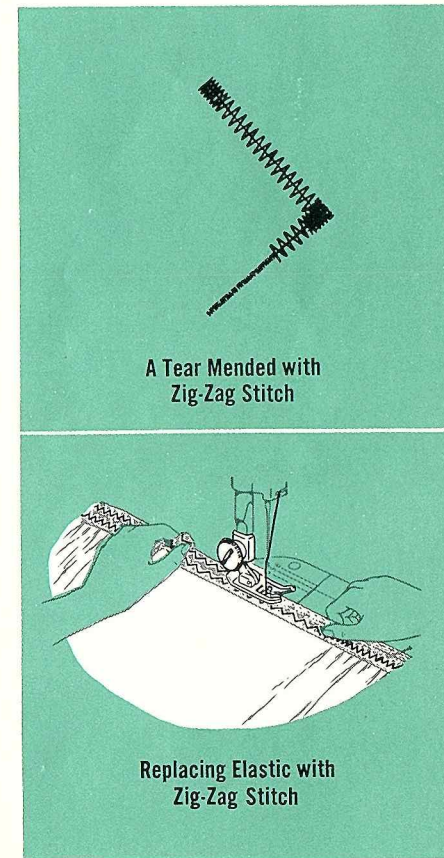

SCRIPT LETTERING

If you wish to embroider a whole name — on a child's dress or shirt, for example — you can do so by free-motion stitching.

Pattern Selector: WWWWWW

Stitch Width: 2-4

Needle Position: C

Stitch Length: FINE (above 20)

Presser Foot: None

Throat Plate Lifter *under* Throat Plate

1. Always make a sample first, to find the right stitch settings and spacing.
2. Trace or mark lettering on right side of fabric.
3. If the fabric is soft or loosely woven, add an underlay of crisp lawn or organdy.
4. Place work in embroidery hoop large enough to encompass the entire design. Be sure fabric is held taut.
5. Position work under needle and lower presser bar to engage tension.
6. Turn hand wheel toward you to bring bobbin thread up through fabric at start of design and hold both threads to start stitching.
7. Stitch, following outline of lettering. Maintain an even rate of speed so that stitches are uniformly spaced.

To produce a close satin stitch, move hoop slowly; to produce an open stitch, move hoop more rapidly.

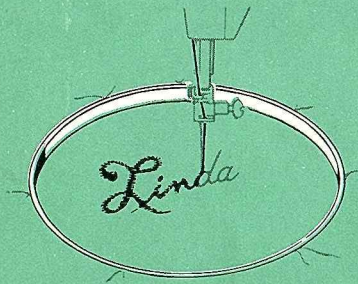
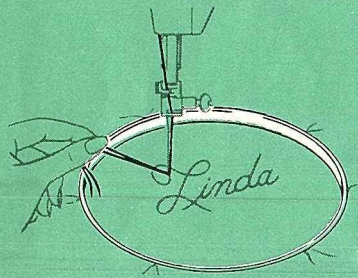

Script Lettering

Adjusting Pressure

The Pressure Screw regulates the pressure that the presser foot exerts on the fabric.

Correct pressure is important because it enables the fabric to feed smoothly and evenly, without being marred. The numbered settings on the pressure gauge will assist you in obtaining the correct pressure for the fabric you are using. Generally, heavier fabrics require a high number setting (heavier pressure); lightweight fabrics, a lower setting (lighter pressure). But fabric texture must also be considered. Soft fabrics, for example, require less pressure than crisp fabrics.

- To *increase* pressure, turn screw downward.
- To *decrease* pressure, turn screw upward.
- To *darn* (without an embroidery hoop), reduce pressure to 0.

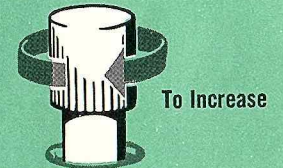
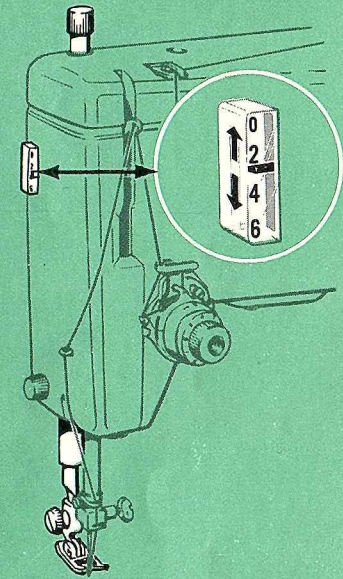

Adjusting Needle-thread Tension

The tension dial regulates the degree of tension on your needle thread. Set it according to the type of thread and fabric you use. The numbers eliminate guesswork in duplicating settings.

Correct tension is important because too much or too little will weaken your seams or cause your fabric to pucker. Make a test sample with the fabric and thread you plan to use and examine it. A perfect stitch will have the needle and bobbin threads locked between the two layers of fabric with no loops on top or bottom, and no puckers.

If stitches look loose, increase needle-thread tension. If the fabric puckers, decrease tension.

- To *increase* tension, turn dial to higher number.
- To *decrease* tension, turn dial to lower number.

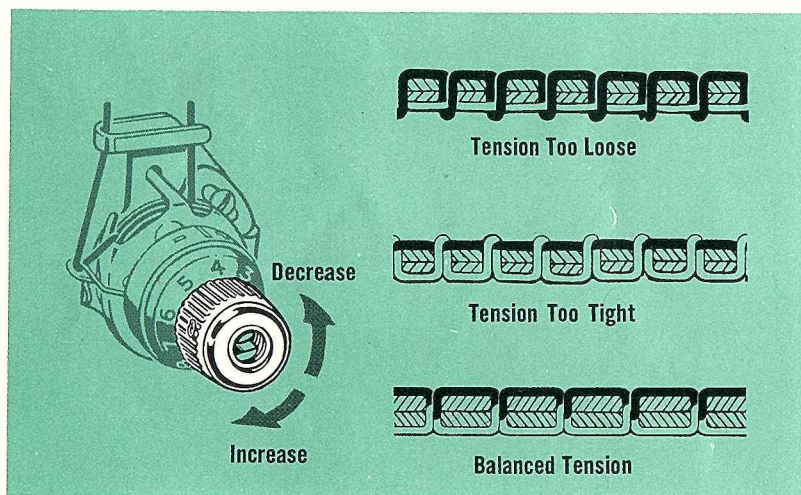
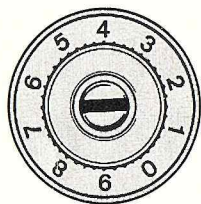

A Word About Free-Motion Work

Decorative designs of all kinds can be effectively accomplished with zig-zag stitching when the free-motion principle is used.

The design is placed in an embroidery hoop to hold the fabric taut. Then, with the presser foot removed from the machine, the hoop is moved slowly so that the needle follows the outline of the design. For all free-motion work be sure to use the Throat Plate Lifter as instructed on page 40.

Stitches can be shaded from wide to narrow by controlling the angle at which the work is placed and moved under the needle.

The application of free-motion work to script lettering is given on the following page. Free-motion stitching is also extremely useful for darning (see page 44 for instructions on free-motion darning).

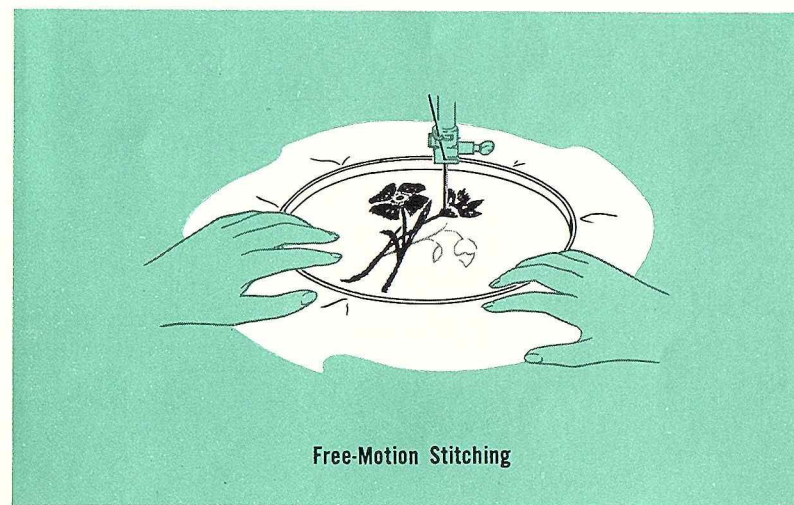

EMBROIDERY

Using the Throat Plate Lifter

The throat plate lifter, used under the throat plate, prevents the feed dog from moving the fabric and thus is used for free-motion darning and embroidery.

- **To insert**, simply open the slide plate, place the lifter in the slideway and close the slide plate. The lifter will slide into place under the throat plate, raising it above the feed dog.
- **To remove**, open the slide plate and pull the lifter forward in the slideway by means of the horizontal bar.

To Remove Presser Foot:

1. Raise the presser foot.
2. Loosen the presser foot screw. (You do *not* need to remove the screw.)
3. Remove the presser foot.

To Replace Presser Foot:

1. Hook presser foot around presser bar.
2. Tighten presser foot screw.

Adjusting Bobbin-thread Tension

Bobbin-thread tension is controlled by a screw located on the bobbin case. You will seldom need to adjust bobbin-thread tension since it is usually possible to obtain the correct balance by adjusting the needle-thread tension alone.

On those rare occasions when it becomes necessary to adjust the bobbin-thread tension, use a small screwdriver. A very slight turn on the screw nearest the thread slot on the bobbin case will produce a noticeable change in bobbin-thread tension.

- To *increase* tension, turn screw clockwise.
- To *decrease* tension, turn screw counterclockwise.

The screwdriver illustrated is available for separate purchase at your SINGER CENTER.

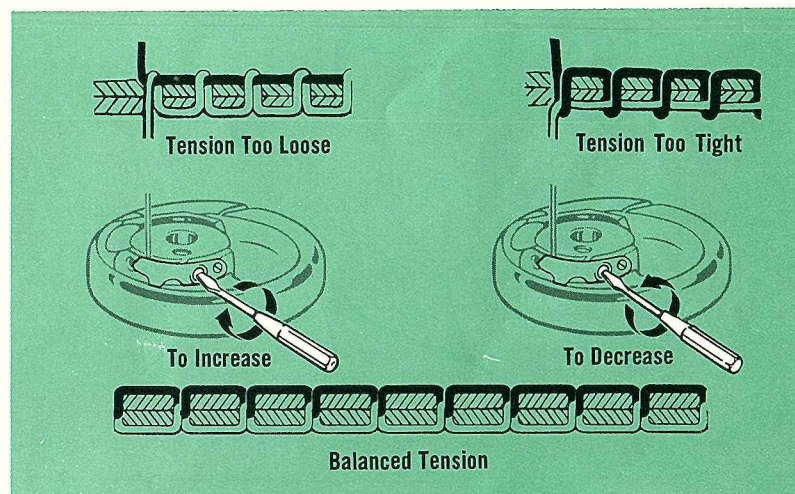

HOW TO SEW A SEAM

To Start a Seam

1. Set Stitch Length Selector for desired number of stitches per inch.
2. With presser foot up, align fabric with appropriate seam guideline on throat plate (as described on the following page). Position needle in fabric about 1/2 inch from the edge.

3. Lower presser foot and raise Stitch Length Selector to reverse.
4. Backstitch to edge of material for reinforcement.

5. Lower Stitch Length Selector for forward stitching, and stitch.

Method #2

Pattern Selector: WWWWWW
 Stitch Width Selector: 0
 Needle Position Selector: C

1. Outline the entire design with a short straight stitch.
2. Trim raw edges to the stitching.
3. Adjust Stitch Width Selector to desired width setting for applique stitch. Set Stitch Length Selector on FINE.
4. Stitch, following and covering the straight-stitch outline. This step will produce a smooth overedged finish, with no raw edges to be trimmed. Remove basting.

Method #2
 Zig-Zag Stitching after Trimming

APPLIQUE

Applique adds beauty and interest to clothes and household linens. Either contrasting or self fabric can be used effectively.

A closed zig-zag stitch is used for machine applique. The width of this stitch can be varied to accommodate fabrics of different weaves and textures.

There are two methods of appliquing: trimming after stitching or stitching after trimming. To decide which method you wish to use, make a sample to see which is most appropriate for your fabric and design.

- Position the design
- Baste it to the fabric

Method #1

1. Set Pattern Selector at (WWWWW).
2. Set stitch width at desired setting, and set stitch length on FINE (above 20).
3. Stitch, outlining the design with applique stitching.
4. Trim any excess fabric on the outer edges of the stitching. Remove basting.

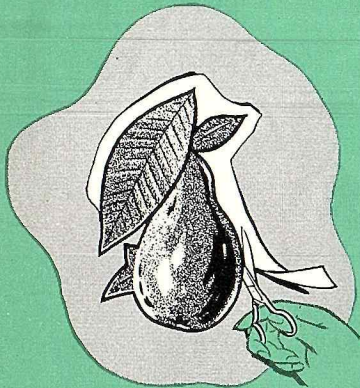

Method #1
Trimming after Zig-Zag Stitching

To Keep the Seam Straight

As you stitch, use one of the numbered lines on the throat plate as a guide to keep the seams straight. Numbers indicate distance, in 8ths of an inch, from the needle. If you want a $\frac{5}{8}$ inch seam, for example, line up your fabric with line 5.

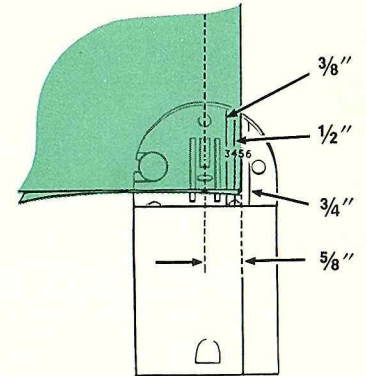

To Guide and Support Fabric

Most fabrics need to be guided in front of the presser foot only, as shown.

Some fabrics, however, require support while being stitched:

- For filmy sheers, knits, etc., apply *gentle* tension by holding seam in front and back of the presser foot.
- For stretch fabrics, apply *firm* tension front and back when stitching in the same direction as the stretch. For seams not on the stretch direction, stitch in conventional manner, guiding fabric in front of presser foot.

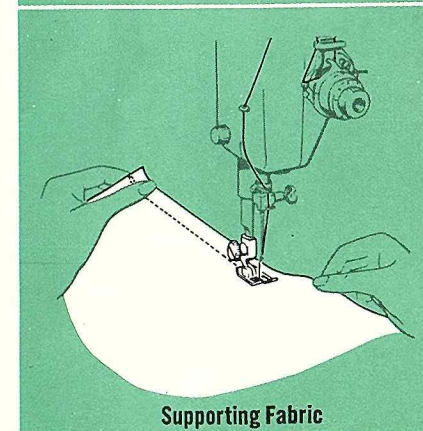
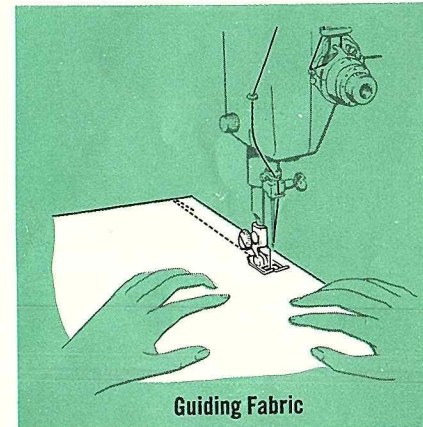

To End a Seam

1. Stitch to the fabric edge. Raise Stitch Length Selector as far as it will go, and backstitch to reinforce end of seam.

2. Turn hand wheel to bring needle to its highest point.

3. Raise presser foot and remove fabric.

4. Cut threads on thread cutter at rear of presser bar. Lower Stitch Length Selector for forward stitching.

Side Stitching:

Readjust Stitch Width Selector for side stitching. Complete work to point E. Leave needle in fabric.

Final Bar Tack:

Adjust Stitch Width Selector for bar tacks, and take at least six stitches ending at point F.

Fastening Stitch:

To secure stitching, move Selector to 0 and take three stitches. Remove work, draw threads to underside, fasten and trim. Cut opening for button with sharp scissors.

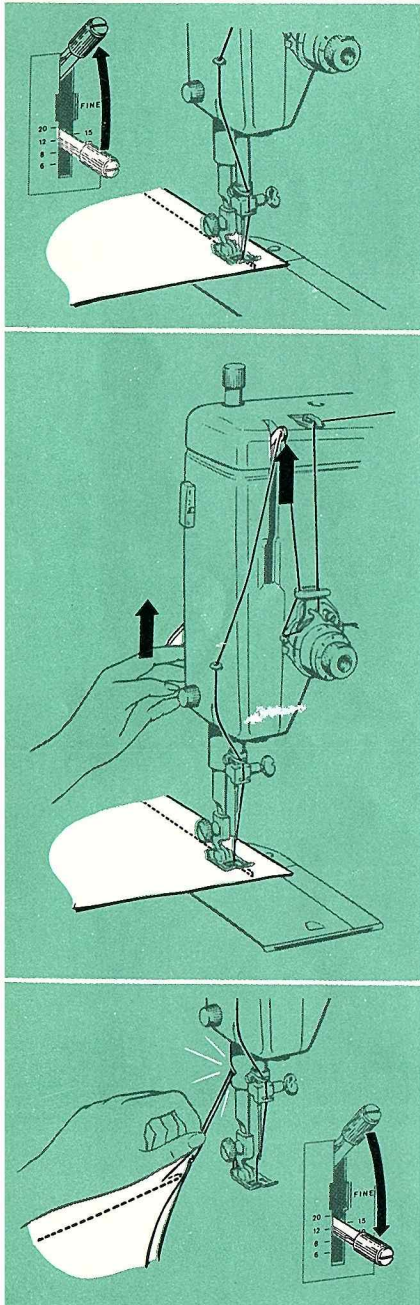
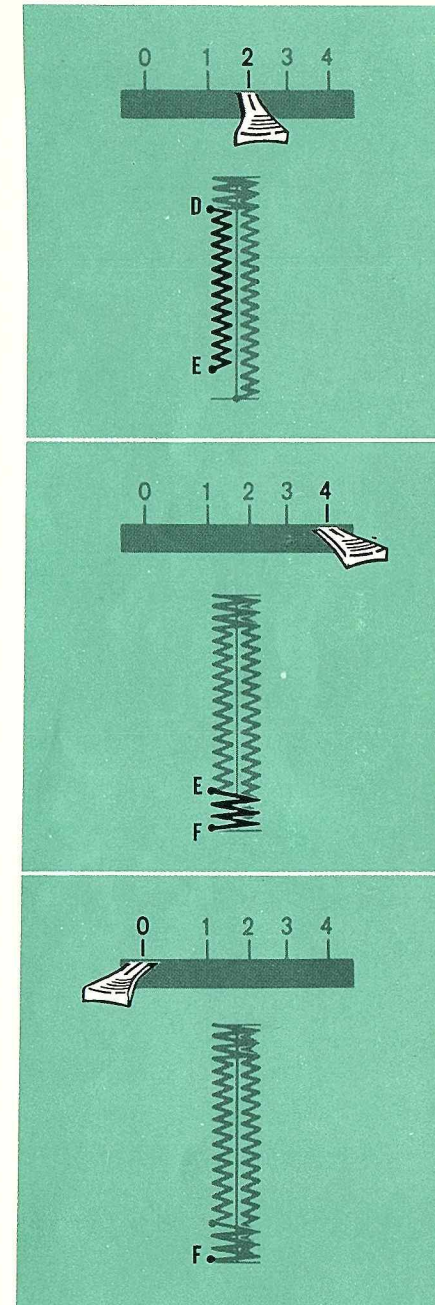

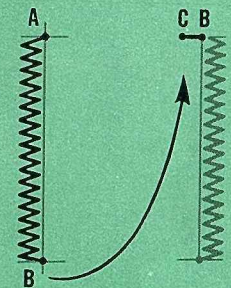

Procedure:

Set Pattern Selector at (WWWWWW), Needle Position Selector at LEFT and Stitch Width Selector at 2. Place work under needle, aligning center marking of buttonhole with slot in the presser foot.

Side Stitching:

Position needle in fabric at point A. Lower foot and stitch to end of marking. Leave needle in fabric at point B. Raise foot and pivot work on needle. Lower foot. Take one stitch without changing width setting, bringing work to point C.

Bar Tack:

Adjust Stitch Width Selector for bar tacks and take at least six stitches. Stop at point D.

4. Zig-Zag stitching

Stitch Width: 1 - 4

Needle Position: C

With your *Style-Mate* sewing machine you can do two kinds of zig-zag stitching: plain zig-zag and blindstitching.

The Pattern Selector, located above the Stitch Width Selector on the front of the machine, controls stitch selection. Set the Stitch Width Selector on 0 before rotating the Pattern Selector dial.

HOW TO SET PATTERN SELECTOR

For Plain Zig-Zag Stitching

- Rotate selector dial toward (WWWWWW).

For Blindstitching

- Rotate selector dial toward (Λ...Λ...).

HOW TO SET STITCH WIDTH AND NEEDLE POSITION

To produce a plain zig-zag stitch or a blindstitch, the Stitch Width Selector must be moved from its straight stitch position 0, to any setting between 1 and 4. The higher the number you select, the wider your stitch will be.

Be sure to raise the needle above the throat plate and fabric before changing the stitch width.

Most of your zig-zag stitching will be done at center needle position; left and right settings are used for special stitching requirements, such as buttonhole making and button sewing.

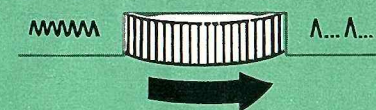
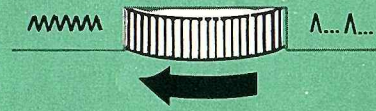
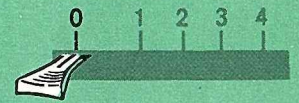

To Set
Pattern Selector

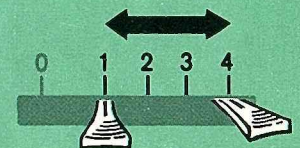

Stitch Width Selector



Needle Position Selector

HOW TO SET STITCH LENGTH AND NEEDLE-THREAD TENSION

When you are preparing to do plain zig-zag stitching or blindstitching, make a test sample with the fabric and thread you plan to use so that you can adjust your stitch length and needle-thread tension properly. If you need to adjust pressure, see page 15.

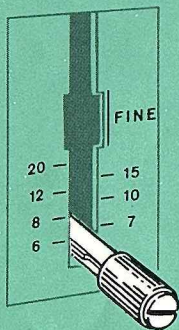

Stitch Length

For open zig-zag stitching, choose any stitch length from 6 to 20, depending on how open you wish the stitching to be. If you wish a closely packed plain zig-zag stitch:

1. Move Stitch Length Selector to bottom of FINE area.
2. Run machine at slow speed.
3. Gradually tighten thumb nut by turning it to right, until stitches are closely spaced and form a smooth surface.

Needle-thread Tension

All zig-zag stitching requires less tension than straight stitching; and closed zig-zag stitching requires even less tension than open zig-zag stitching. Furthermore, the wider the stitch, the lighter the tension on the thread must be. Thus, stitch width 4 requires the least tension; narrower stitching requires somewhat more.

Notice the stitching on your sample. If the stitching looks too taut, or if the fabric is puckering, lower the needle-thread tension by turning the Tension Dial to a lower number.

BUTTONHOLES

Pattern Selector: WWWWWW

Stitch Width: 2 and 4

Needle Position: L

Stitch Length: FINE (above 20)

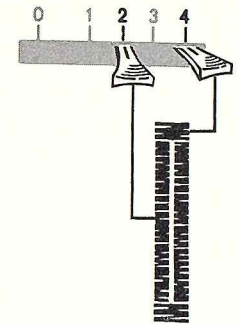

Always make a test buttonhole on a sample of your fabric. Be sure to duplicate the thickness of the garment and include interfacing if appropriate.

Stitch Width Settings:

You will use two stitch width settings: for side stitching a stitch width of 2 and for the bar tacks (the closings at each end of buttonhole) a stitch width of 4.

Buttonhole Length:

How long the opening needs to be will depend on the diameter and thickness of the button. To find the right length:

1. Cut a small hole in a scrap of your fabric and gradually enlarge it until the button slips through easily.
2. Add at least $\frac{1}{8}$ inch ($\frac{1}{16}$ inch for each bar tack), and mark the fabric as shown.

This bar-tack measurement is approximate; on some buttonholes, you may need to increase it to arrive at pleasing proportions.

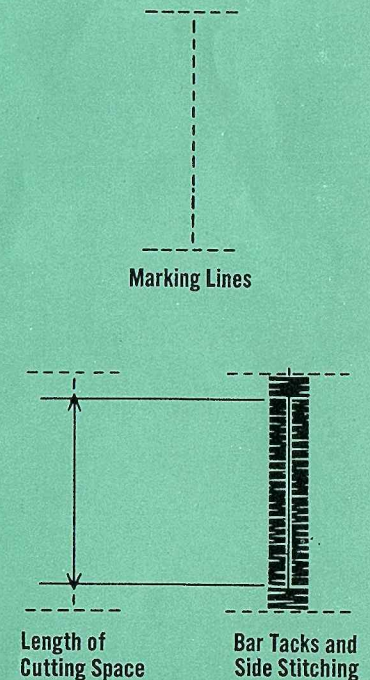

BUTTONS

Pattern Selector: 

Stitch Width: 0 and 4

Needle Position: L

Throat Plate Lifter *under* Throat Plate

The space between the holes in the button determines the stitch width settings. The 0 setting must always be used while positioning the needle over the left hole in the button and fastening stitching. For buttons with standard hole spacing, settings 0 and 4 are usually satisfactory. For buttons with narrow hole spacing, use setting 0 and decrease the width setting as necessary. To sew on two or four hole buttons, approximately one inch in diameter or larger:

1. Insert throat plate lifter, see page 40.
2. Set stitch width at 0. Position button under foot and lower the needle into the center of the left hole. Lower the foot. Turn hand wheel toward you until needle rises out of button and is just above the foot.
3. Set stitch width at 4. Then, when you begin to stitch, the needle should enter into the right hole of the button. Take six or more zig-zag stitches at this setting. End on the left side.
4. To fasten stitching, return to stitch width 0 and take about three stitches.

For best results, and when using buttons smaller than one inch in diameter, it is recommended that the Button Sewing Presser Foot (available for separate purchase) be used — see page 55.

5. Two-needle stitching

By using two needles at once, you can produce two parallel, closely spaced, decorative lines of stitching simultaneously. You can use either one or two colors of thread; and you can choose either a straight-stitch, zig-zag stitch or blindstitch setting.

HOW TO SET THE MACHINE

Straight Stitching

Stitch Width: 0

Needle Position: C or L only

Zig-Zag Stitching

Pattern Selector:  (for Zig-Zag)

or

 (for Blindstitch)

Stitch Width: 1-2½ (maximum)

Needle Position: L only

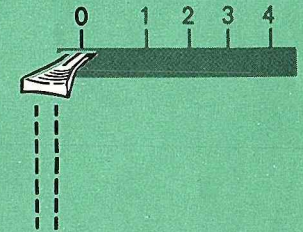

Straight Stitching

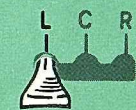
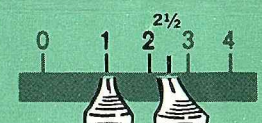
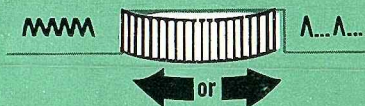

Zig-Zag Stitching

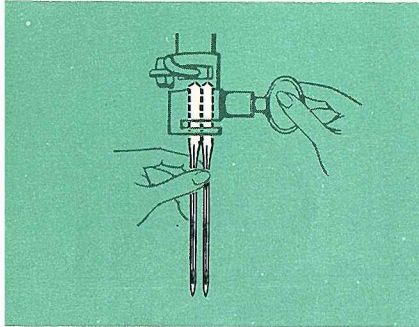

HOW TO INSERT SECOND NEEDLE

The needle clamp easily accommodates two needles, Catalog 2020 (15 X 1). Best stitching results will be obtained with size 14.

To insert the second needle, simply loosen the needle clamp screw and insert the needle from the right.

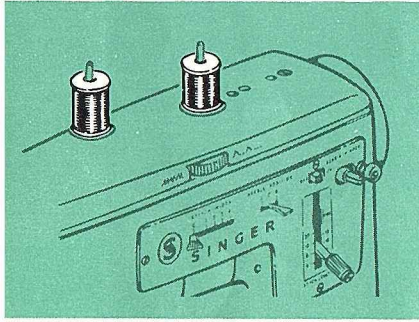

HOW TO THREAD THE MACHINE

For best results, use No. 50 Mercerized cotton thread.

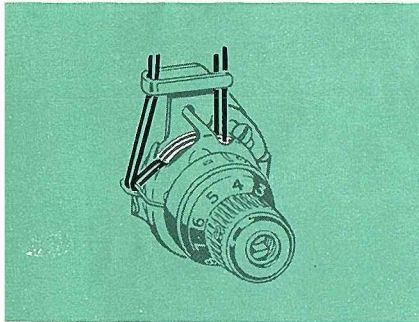

Thread the machine in the same manner as for single-needle stitching except:

1. Be sure that threads are separated by center tension disc as they pass around assembly.

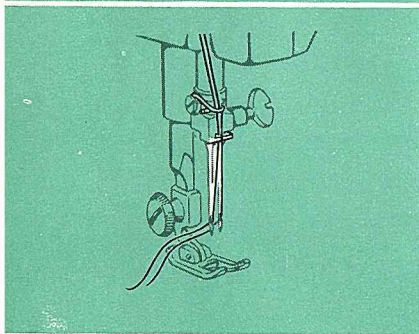

2. Carry only one thread through the last thread guide before the needle.

DARTS

Regular Darts

Stitch Width: 0

Needle Position: C

Stitch Length: About 12 or to suit fabric

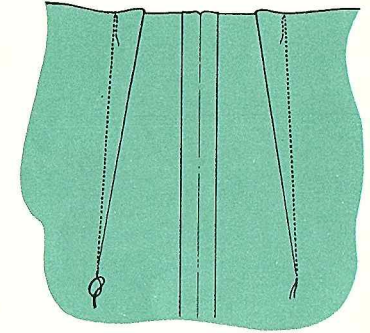

Regular Dart

1. Stitch from the seam edge, tapering gradually to the point.
2. Stitch beyond the fabric to form a thread chain $\frac{1}{2}$ to $\frac{3}{4}$ inch long.
3. Tie the thread ends into a single knot close to the stitching.

Darts in Interfacing

Pattern Selector: 

Stitch Width: 4

Needle Position: C

With zig-zag stitching, interfacings can be shaped without bulk.

1. Cut out the dart allowance on the stitching line.
2. Bring raw edges together and pin over a muslin stay.
3. Stitch, backstitching at both ends.

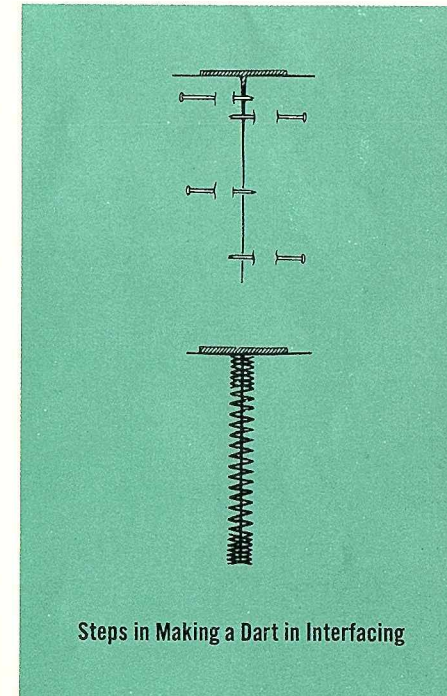

Steps in Making a Dart in Interfacing

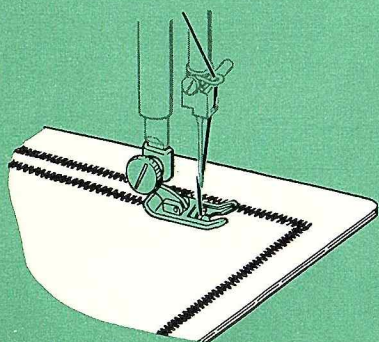

Top Stitching

TOP STITCHING

A practical, simple way to accent the lines of a dress or coat is to place one or more rows of stitching along collars, lapels, facing edges, pockets, sleeves, etc. For a tailored look, use lines of straight stitching. For decorative interest, use zig-zag stitching.

SHELL EDGING

Pattern Selector: \wedge ... \wedge ...

Stitch Width: To suit fabric

Needle Position: **C**

Stitch Length: To suit fabric

On soft, fine fabrics, shell edging makes an attractive finish for narrow hems or bias folds.

1. Make a test on a sample of your fabric to find the right thread tension, stitch length, and stitch width.
2. Place folded hem (basted, if necessary) or bias fold under presser foot, with hem or fold toward the left.
3. Stitch slowly, guiding fabric by hand so that the sideward stitches do not pierce the folded edge.

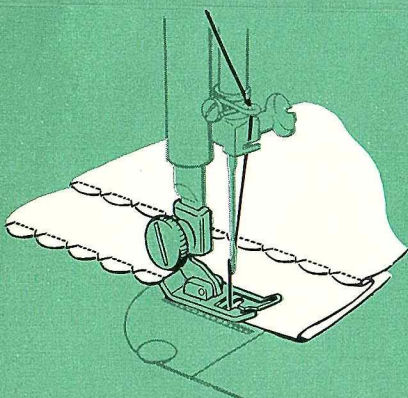

Shell Edging

6. Clothes and home decorations

SEAMS

Pin Basting

Pin basting is a time saver and can be used in place of hand basting when you are straight stitching seams in easy-to-handle fabrics. When sewing over pins it is important to use fine pins and to place them correctly in reference to the stitching line.

Place pins so that:

- They are at right angles to the stitching line
- They just nip into the fabric at the stitching line
- There is minimum pin extension beyond the stitching line. Pins should not extend under both sides of the presser foot, and should never be placed on the underside of the fabric in contact with the feed dog.

The Seam Guide is available for separate purchase.

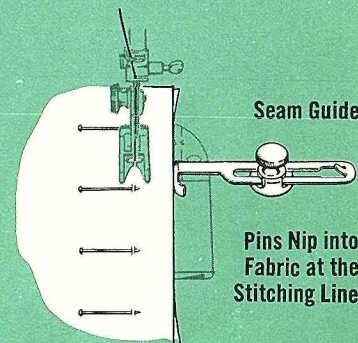

Pin Placement when Seam Guide is used.

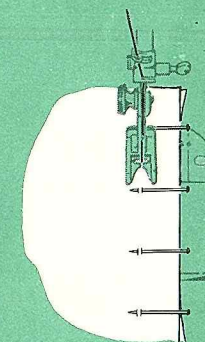

Pin Placement when Seam Guide is NOT used.

Straight Seams

Stitch Width: **0**
 Needle Position: **C**
 Stitch Length: **6-20**, depending
 on fabric

1. Pin seam edges together or baste if necessary. If you pin baste, place pins as instructed on page 25 so that the hinged presser foot will ride freely over the points.
2. If you use the Seam Guide (available for separate purchase), align edge of guide with presser foot. Guide the fabric edges lightly against the guide while stitching.

Curved Seams

Follow the same steps as for straight seams *except*:

1. Use a short stitch length for elasticity and strength. For example, if you use 12 stitches per inch for straight seams, select 15 to 20 per inch to stitch curved seams in the same fabric.
2. If you use the Seam Guide, attach it at an angle so that the edge closer to the needle acts as a guide.

BLINDSTITCH HEMS

Pattern Selector: $\wedge \dots \wedge \dots$
 Stitch Width: **2-4**
 Needle Position: **C**
 Stitch Length: **10-15**

Blindstitching provides a durable hem finish that is virtually invisible and is comparable to hand sewing. It is best suited to straight and slightly curved hems. Taped, bound, turned, or unfinished hem edges can be blindstitched with equal ease.

1. Mark, turn, and press hem.
2. Baste a guideline $\frac{1}{4}$ inch from the top of the hem edge.
3. Place hem edge over the feed of the machine, turning bulk of fabric to the left and thus creating a soft fold.
4. Stitch so that straight stitches fall on the hem edge and sideward zig-zag stitches pierce the soft fold.

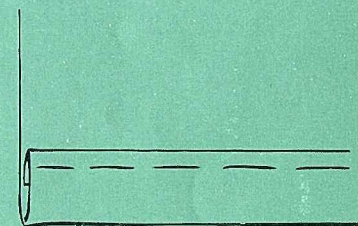

Basted Guideline

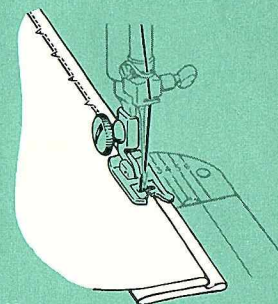

Blindstitch Hem

Seam Finishes

Pattern Selector: WWWWWW (for Zig-Zag)

or

^...^...^ (for Blindstitch)

Stitch Width: To suit fabric, 2-4

Needle Position: C

Stitch Length: 8-20, depending on choice of stitch and fabric

Seam edges support the garment and should be given a durable finish if the fabric is likely to ravel.

1. Make a test sample first to determine whether zig-zag stitch (WWWWWW) or blindstitch (^...^...^) best suits your fabric.
2. Adjust stitch length and stitch width settings to suit fabric. Choose the settings that will give you the most "open" stitch that will secure the fabric edges; avoid harsh, over-stitched edges.
3. Place stitching *near* the edge of the seam allowance or *over* the raw edge as illustrated.
4. If stitching is placed near the edge of the seam allowance, trim edges evenly after stitching.

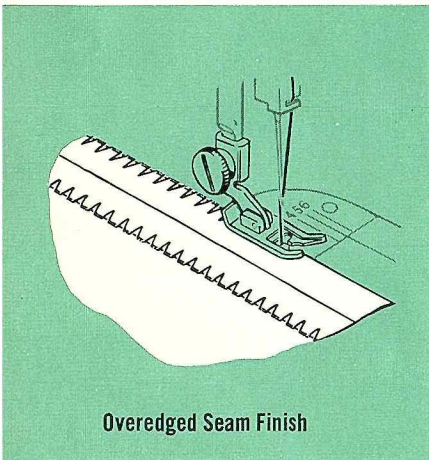
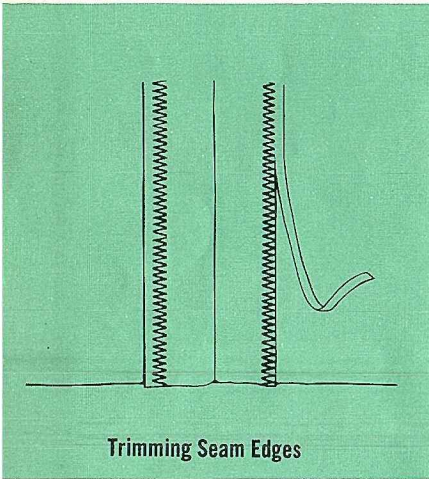

Lingerie Seams

Pattern Selector: WWWWWW

Stitch Width: 1½-2

Needle Position: C

Stitch Length: 15-20 depending on fabric.

To make a lingerie seam both durable and flexible, use a zig-zag stitch. This treatment is particularly suitable for bias seams.

1. Straight-stitch the seam (with Stitch Width at 0) on wrong side.
2. Press both seam allowances in the same direction.
3. From the right side, top-stitch with zig-zag pattern (with Stitch Width at 1½), letting the needle alternately enter the seam line and seam thickness.

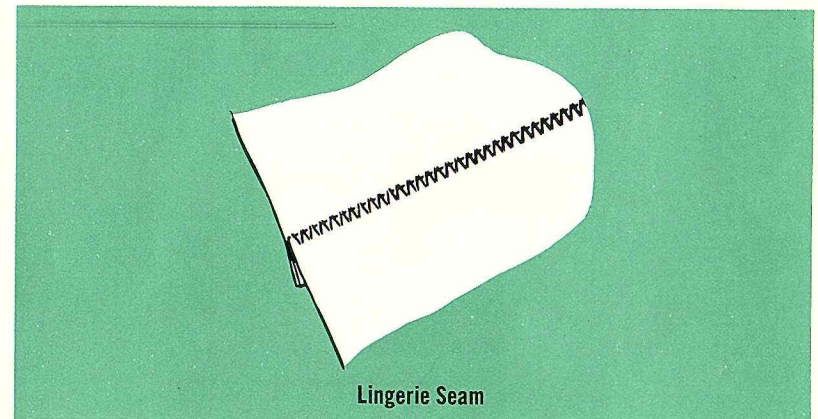

Seams in Knit Fabrics

Pattern Selector: WWWWWW

Stitch Width: 2

Needle Position: C

Stitch Length: About 20

A fine zig-zag stitch is ideal for seaming knit fabrics. It is particularly desirable for underarm seams where elasticity and give are needed.

However, where a stay is needed to prevent undue stretching at neckline and waistline seams, this same stitch can be used to apply seam tape. For a flat, smooth stayed finish:

1. If seam is curved, pre-shape tape to fit by steam pressing.
2. Baste tape in place.
3. Stitch, allowing needle to enter seam tape and seam allowance alternately.

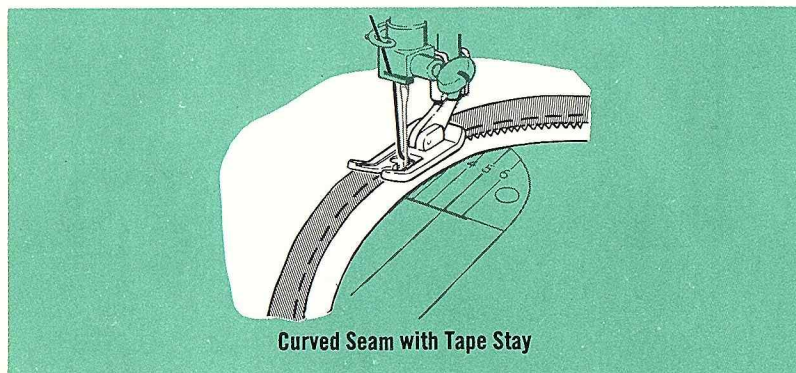

Curved Seam with Tape Stay

Flat Felled Seams

Pattern Selector: WWWWWW

Stitch Width: 1½

Needle Position: C

Stitch Length: 15-20, depending on fabric

Zig-zag stitching gives strength and durability to flat-felled seams.

1. Stitch the seam on the right side of the fabric, taking full seam allowance.
2. Press the seam allowance to one side, keeping the right side of the stitch on top.
3. Trim the under seam allowance to one-half its width.
4. Turn the upper seam allowance edge evenly over the trimmed edge, and top-stitch.

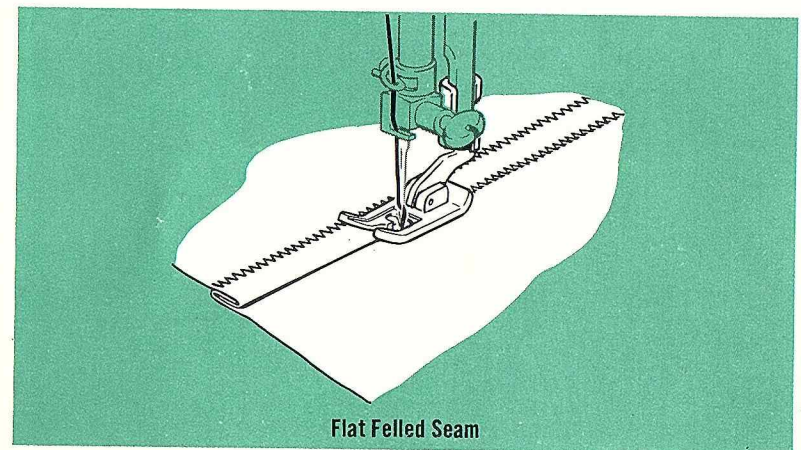

Flat Felled Seam